

Gas Industry Standard

GIS/ PL2-8:2022

Specification for

**Polyethylene pipes and fittings for natural gas and
suitable manufactured gas**

Part 8: Pipes for use at pressures up to 7 bar



Contents

Foreword	ii
Relationship with other publications	ii
Mandatory and non-mandatory requirements	ii
Disclaimer	ii
Brief history	iii
1. Scope	5
2. Normative references	5
3. Terms and Definitions	7
4. Conformance	11
5. Material	11
6. Compound	12
7. General	12
8. Geometry	13
9. Mechanical properties	16
10. Physical properties	19
11. Butt fusion jointing compatibility: fitness-for-purpose	20
12. Maximum operating pressure, overall service (design) coefficient, and design stress.	21
13. Type testing of pipe	21
14. Batch release testing	24
15. Marking	25
16. Delivery conditions	27
Annex - A Method for jointing by offset butt fusion	28
Annex - B Method for electrofusion socket joint de-cohesion (peel) strength (normative)	29
Annex - C Packaging of coiled and drummed pipe (minimum requirements) (normative)	30
Annex - D RCP Testing Procedures for PE100 & PE100/PE100 multilayer orange Pipes (normative)	33
Annex - E Diameters and maximum operating pressures (MOP) for PE100 orange and Multilayer PE100/PE100 polyethylene pipes (normative)	34
Annex - F Type Approval testing of Pipes produced from 100% rework (normative)	35
Annex - G Rapid Crack Propagation (RCP) - Discussion and Requirements (informative)	36
Annex - H Summary of and Rationale for changes to document – December 2014 (increase pipe sizes to 630mm).	53
Annex - I Changes to Document January 2022	54

Foreword

Gas Industry Standards (GIS) are revised, when necessary, by the issue of new editions. Users should ensure that they are in possession of the latest edition. Contractors and other users external to Gas Transporters should direct their requests for copies of a GIS to the department or group responsible for the initial issue of their contract documentation.

Comments and queries regarding the technical content of this document should be directed in the first instance to the contract department of the Gas Transporter responsible for the initial issue of their contract documentation.

This standard calls for the use of procedures that may be injurious to health if adequate precautions are not taken. It refers only to technical suitability and does not absolve the user from legal obligations relating to health and safety at any stage.

Compliance with this engineering document does not confer immunity from prosecution for breach of statutory or other legal obligations.

Relationship with other publications

GIS/PL2 Polyethylene pipes and fittings for natural gas and suitable manufactured gas consists of the following parts:

Part 1: General and polyethylene compounds for use in polyethylene pipes and fittings.

Part 2: Pipes for use at pressures up to 5.5 bar.

Part 3: Butt fusion machines and ancillary equipment.

Part 4: Fusion fittings with integral heating element(s).

Part 5: Electrofusion ancillary tooling.

Part 6: Spigot end fittings for electrofusion and/or butt fusion purposes.

Part 7: Squeeze-off tools and equipment.

Part 8: Pipes for use at pressures up to 7 bar.

Mandatory and non-mandatory requirements

For the purposes of a GIS the following auxiliary verbs have the meanings indicated:

can indicates a physical possibility;

may indicates an option that is not mandatory;

shall indicates a GIS requirement;

should indicates best practice and is the preferred option. If an alternative method is used then a suitable and sufficient risk assessment needs to be completed to show that the alternative method delivers the same, or better, level of protection.

Disclaimer

This engineering document is provided for use by Gas Transporters and such of their contractors as are obliged by the terms of their contracts to comply with this engineering document. Where this engineering document is used by any other party, it is the responsibility of that party to ensure that the engineering document is correctly applied.

Brief history

Edited by BSI in accordance with BS 0-3:1997 Working Group Draft Revision - increase pipe sizes up to 630mm -refer to Annex H Reviewed and updated to include pipe diameters up to 800 mm	July 2006 July 2008 December 2014 January 2022
--	---

© **ENA**, on behalf of Cadent Gas Limited, Gas Networks Ireland, Northern Gas Networks, SGN, and Wales & West Utilities.

This Gas Industry Standard is copyright and must not be reproduced in whole or in part by any means without the approval in writing of either Cadent Gas Limited, Gas Networks Ireland, Northern Gas Networks, SGN, or Wales & West Utilities.

1. Scope

This part of GIS/PL2 specifies requirements for polyethylene pipes, with a strength classification of PE100¹⁾ in the nominal size range 16 mm to 800 mm inclusive for use at operating pressures not greater than 7.0 bar and operating temperatures in the range of 0 °C to 40 °C.

It is applicable to all combinations of PE pipes i.e. unimodal and bimodal for use at pressures not greater than 7 bar and operating temperatures in the range 0 °C to 40 °C.

The multilayer PE pipes shall be extruded from a single die.

NOTE: separate extrusion of the outer layer over the inner layer is not permitted.

The PE100 and PE100/PE100 multilayer pipes are designed to be suitable for butt fusion to GIS/PL2-3 and electrofusion fittings to GIS/PL2-4 with ancillary tooling to GIS/PL2-5.

The PE100 and PE100/PE100 multilayer pipes are designed to be suitable for squeeze-off using tools to GIS/PL2-7 in sizes up to and including 315mm.

It is applicable to pipes for carrying gaseous fuels and in particular natural gas having a composition specified in BS EN ISO 13686 or suitable manufactured gases.

2. Normative references

The following referenced documents are indispensable for the application of this document. For dated references, only the edition cited applies. For undated references, the latest edition of the referenced document (including any amendments) applies.

2.1 British and European standards

BS EN ISO 472, *Plastics — Vocabulary*.

BS EN 728, *Plastics piping and ducting systems. Polyolefin pipes and fittings. Determination of oxidation induction time*.

BS EN ISO 1043-1, *Plastics — Symbols and abbreviated terms — Part 1: Basic polymers and their special characteristics*.

BS EN ISO 1133, *Plastics — Determination of the melt mass-flow rate (MFR) and the melt volume-flow rate (MVR) of thermoplastics – Standard method*.

BS EN ISO 1167 – 1, *Thermoplastics pipes, fittings and assemblies for the conveyance of fluids. Determination of the resistance to internal pressure - General method*.

BS EN ISO 1167 – 2, *Thermoplastics pipes, fittings and assemblies for the conveyance of fluids. Determination of the resistance to internal pressure - Preparation of pipe test pieces*.

BS EN ISO 1183-1, *Plastics – Methods for determining the density and relative density of non-cellular plastics — Part 1: Immersion method, liquid pycnometer method and titration method*.

BS EN ISO 1183-2, *Plastics — Methods for determining the density of non-cellular plastics — Part 2: Density gradient column method*.

BS EN ISO 1183-3, *Plastics — Methods for determining the density of non-cellular plastics — Part 3: Gas pycnometer method*.

BS EN ISO 1872-1, *Plastics — Polyethylene (PE) moulding and extrusion materials — Part 1: Designation system and basis for specifications*

BS EN ISO 2505, *Thermoplastics pipes. Longitudinal reversion. Test methods and parameters*.

BS EN ISO 3126, *Plastic piping systems — Plastic components — Determination of dimensions*.

BS EN ISO 6259-1, *Thermoplastics pipes — Determination of tensile properties — Part 1: General test method*.

¹⁾ PE100 is a material strength classification as determined by BS EN ISO 9080 & BS EN ISO12162.

BS EN ISO 6259-3, *Thermoplastics pipes — Determination of tensile properties — Part 3: Polyolefin pipes.*

BS EN ISO 9080, *Plastics piping and ducting systems. Determination of the long-term hydrostatic strength of thermoplastics materials in pipe form by extrapolation.*

BS EN ISO 9969, *Thermoplastics pipes. Determination of ring stiffness*

BS EN ISO 11357-6, *Differential scanning Calorimetry (DSC) – Part 6: Determination of oxidation induction time (isothermal OIT) and oxidation induction temperature (dynamic OIT).*

BS ISO 11414, *Plastics pipes and fittings – Preparation of polyethylene (PE) pipe/pipe or pipe/fitting test piece assemblies by butt fusion.*

BS EN 12106, *Plastics piping systems — Polyethylene (PE) pipes — Test method for the resistance to internal pressure after application of squeeze off.*

BS EN ISO 12162, *Thermoplastics materials for pipes and fittings for pressure applications. Classification, designation and design coefficient.*

BS EN ISO 13477, *Thermoplastics pipes for the conveyance of fluids — Determination of resistance to rapid crack propagation (RCP) — Small-scale steady-state test (S4 test).*

BS EN ISO 13478, *Thermoplastics pipes for the conveyance of fluids — Determination of resistance to rapid crack propagation (RCP) — Full scale test (FST).*

BS EN ISO 13479, *Polyolefin pipes for the conveyance of fluids — Determination of resistance to crack propagation — Test method for slow crack growth on notched pipes (notch test).*

BS EN ISO 13686, *Natural gas – Quality designation.*

BS ISO 13953, *Polyethylene (PE) pipes and fittings — Determination of the tensile strength and failure mode of test pieces from a butt-fused joint.*

BS ISO 13954, *Plastics pipes and fittings — Peel decohesion test for polyethylene (PE) electrofusion assemblies of nominal outside diameter greater than or equal to 90 mm.*

BS ISO 13955, *Plastics pipes and fittings. Crushing decohesion test for polyethylene (PE) electrofusion assemblies*

BS EN ISO 13968, *Plastics piping and ducting systems – Thermoplastic pipes – Determination of ring stiffness.*

BS EN ISO/IEC 17025, *General requirements for the competence of testing and calibration laboratories.*

ISO 3, *Preferred numbers. Series of preferred numbers*

ISO 497, *Guide to the choice of series of preferred numbers and of series containing more rounded values of preferred numbers*

2.2 Gas Industry Standards

GIS/PL2-1, *Specification for polyethylene pipes and fittings for natural gas and suitable manufactured gas — Part 1: General and polyethylene compounds for use in polyethylene pipes and fittings.*

GIS/PL2-2, *Specification for polyethylene pipes and fittings for natural gas and suitable manufactured gas — Part 2: Pipes for use at pressures up to 5.5 bar.*

GIS/PL2-3, *Specification for polyethylene pipes and fittings for natural gas and suitable manufactured gas — Part 3: Butt fusion machines and ancillary equipment.*

GIS/PL2-4, *Specification for polyethylene pipes and fittings for natural gas and suitable manufactured gas — Part 4: Fusion fittings with integral heating element(s).*

GIS/PL2-5, *Specification for polyethylene pipes and fittings for natural gas and suitable manufactured gas — Part 5: Electrofusion ancillary tooling.*

GIS/PL2-7, *Specification for polyethylene pipes and fittings for natural gas and suitable manufactured gas — Part 7: Squeeze-off tools and equipment.*

3. Terms and Definitions

For the purposes of this specification the terms and definitions, symbols, abbreviations and units given in BS EN ISO 472 and BS EN ISO 1043-1 and the following apply.

3.1 Contractor

The person, firm or company with whom a Gas Transporter enters into a contract to which this Standard applies, including the Contractor's personal representatives, successors and permitted assigns.

3.2 Geometrical definitions

3.2.1 nominal size (DN)

numerical designation of the size of a component, other than a component designated by thread size, which is a convenient round number, approximately equal to the manufacturing dimension in millimetres (mm)

3.2.2 nominal size (DN/OD)

nominal size, related to the outside diameter

3.2.3 nominal outside diameter, d_n

specified outside diameter, in millimetres, assigned to a nominal size DN/OD

3.2.4 outside diameter (at any point), d_e

value of the measurement of the outside diameter through its cross-section at any point of the pipe, rounded to the next greater 0.1 mm

3.2.5 mean outside diameter, d_{em}

value of the measurement of the outer circumference of the pipe or spigot end of a fitting in any cross-section divided by π ($= 3.142$), rounded to the next greater 0.1 mm

3.2.6 minimum mean outside diameter, $d_{em, min}$

minimum value for the mean outside diameter as specified for a given nominal size

3.2.7 maximum mean outside diameter, $d_{em, max}$

maximum value for the mean outside diameter as specified for a given nominal size

3.2.8 ovality

difference between the maximum and the minimum outside diameter in the same cross-section of a pipe or spigot, rounded off to the nearest 0.1 mm

3.2.9 loss of roundness

loss of pipe diameter, not caused by distortion (ovality), normally caused by surface damage and abrasion

3.2.10 circumferential reversion

reduction in pipe diameter near the pipe ends produced by internal axial stresses in the pipe wall and caused by variations in cooling rates

3.2.11 nominal wall thickness, e_n

numerical designation of the wall thickness of a component, which is a convenient round number,

approximately equal to the manufacturing dimension in millimetres (mm)

NOTE For thermoplastics components, the value of the nominal wall thickness, e_n , is identical to the specified minimum wall thickness, e_{min} .

3.2.12 wall thickness (at any point), e

wall thickness at any point around the circumference of a component

3.2.13 minimum wall thickness (at any point), e_{min}

minimum value for the wall thickness around the circumference of a component, as specified

3.2.14 maximum wall thickness (at any point), e_{max}

maximum value for the wall thickness around the circumference of a component, as specified

3.2.15 mean wall thickness, e_m

arithmetical mean of a number of measurements of the wall thickness, regularly spaced around the circumference and in the same cross-section of a component, including the measured minimum and the measured maximum values of the wall thickness in that cross-section

3.2.16 tolerance

permitted variation of the specified value of a quantity, expressed as the difference between the permitted maximum and the permitted minimum value

3.2.17 wall thickness tolerance

permitted difference between the wall thickness at any point, e , and the nominal wall thickness, e_n

NOTE $e_n = e_{min}$.

3.2.18 standard dimension ratio (SDR)

numerical designation of a pipe series, which is a convenient round number, approximately equal to the dimension ratio of the nominal outside diameter, d_n , and the nominal wall thickness, e_n

3.3 Material definitions

3.3.1 virgin material

material in a form such as granules/pellets that has not been subjected to use or processing other than that required for its manufacture and to which no reprocessable or recyclable materials have been added

3.3.2 own reprocessable (rework) material

material prepared from clean rejected unused pipes, fittings or valves, including trimmings from the production of pipes, fittings or valves, that will be reprocessed in a manufacturer's plant after having been previously processed by the same manufacturer in the production of components by, for example injection moulding or extrusion

3.3.3 compound

homogenous mixture of base polymer (polyethylene) and additives, i.e. antioxidants, pigments, UV-stabilizers and others, at a dosage level necessary for the processing and use of components conforming to the requirements of this standard

3.3.4 campaign batch

uninterrupted base polymer production run by the resin manufacturer

NOTE: It should not exceed 1 month's production.

3.3.5 compound batch

clearly identifiable quantity of a given homogeneous compound manufactured under uniform

conditions

NOTE: The compound batch is defined and identified by the compound manufacturer. It should not exceed 700 tonnes.

3.3.6 pipe batch

number of pipes, all of them of the same nominal outside diameter, wall thickness and marking, extruded from the same compound on the same machine. A batch of pipe should not exceed 7 days continuous production.

NOTE: An extrusion equipment breakdown lasting >14hrs constitutes a new pipe batch.

3.3.7 layer

one or more windings of pipe having the same coil diameter

3.3.8 inner layer

layer in contact with the conveyed fluid

3.3.9 outer layer

layer exposed to the outer environment

3.3.10 multilayer PE100 pipe

pipes consisting of two stress designed layers. It is a co-extruded black PE100 inner layer and an orange PE100 outer layer. The PE100/PE100 multilayer co-extruded pipe shall be treated for this specification's requirements as a single pipe, even though there are two layers of different PE100 grades/colours

3.3.11 BRT

batch release test (BRT) testing performed by the manufacturer on a batch of material or components, which has to be satisfactorily completed before the batch can be released.

3.3.12 PVT

process verification test (PVT) testing performed by the manufacturer on material, components, and assemblies at specific intervals to confirm that the process continues to be capable of producing components conforming to the requirements given in the relevant standard.

3.3.13 TT

type testing (TT) testing performed to prove that the material, component, assembly is capable of conforming to the requirements given in the relevant standard.

3.4 Material properties

3.4.1 lower predicted limit (LPL), σ_{LPL}

quantity, with the dimensions of stress in megapascals (MPa), which can be considered as a property of the material, and represents the 97.5 % lower predicted limit of the mean long term strength at 20 °C for 50 years with internal water pressure

3.4.2 minimum required strength (MRS)

value of σ_{LPL} , rounded down to the next smaller value of the R10 series or of the R20 series depending on the value of σ_{LPL}

NOTE R10 and R20 series are the Renard number series according to ISO 3 and ISO 497.

3.4.3 overall service (design) coefficient or safety factor, C

allowable hoop or circumferential stress C should have a minimum value/safety factor of 2.9 which takes into consideration service conditions as well as properties of the components of a piping system other than those represented in the lower confident limit.

3.4.4 design stress, σ_s

allowable stress in megapascals (MPa) for a given application

NOTE: It is derived from the MRS by dividing it by the coefficient C, i.e.:

$$\sigma_s = \frac{\text{MRS}}{C}$$

3.4.5 melt-mass flow rate (MFR)

value relating to the viscosity of the molten material at a specified temperature and load, expressed in grams per 10 min (g/10 min)

3.5 Service conditions

3.5.1 gaseous fuel

any fuel which is in gaseous state at a temperature of 15 °C, at atmospheric pressure

3.5.2 maximum operating pressure (MOP)

maximum effective pressure of the fluid in the piping system, expressed in bar, which is allowed in continuous use. It takes into account the physical and the mechanical characteristics of the components of a piping system

NOTE It is calculated using the following equation:

$$\text{MOP} = \frac{20 \times \text{MRS}}{C \times (\text{SDR} - 1)}$$

3.5.3 reference temperature

temperature for which the piping system is designed

NOTE It is used as the base for further calculation when designing a piping system or parts of a piping system for operating temperatures different from the reference temperature.

3.6 Joints

3.6.1 butt fusion joint (using heated tool)

joint made by heating the planed ends of pipes or spigot end fittings

NOTE The surfaces of the joint match by holding them against a flat heating plate until the polyethylene material reaches fusion temperature, removing the heating plate quickly and pushing the two softened ends against one another.

3.6.2 fusion compatibility

ability of two similar or dissimilar polyethylene materials to be fused together to form a joint which conforms to the performance requirements of this standard

3.7 Packaging

3.7.1 coiled pipe

pipe extruded in a multi-layer coiled configuration with the layers strapped together to provide a stable and self-supporting unit

3.7.2 drummed pipe

pipe extruded on to a rigid framed reel, with a supporting centre core to which the pipe is anchored
Drummed pipe shall be dispensed from a trailer or low loader.

3.8 Symbols

C overall service (design) coefficient

d_e	outside diameter (at any point)
d_{em}	mean outside diameter
$d_{em,max}$	maximum mean outside diameter
$d_{em,min}$	minimum mean outside diameter
d_n	nominal outside diameter
e	wall thickness (at any point) of a pipe
e_m	mean wall thickness
e_{max}	maximum wall thickness (at any point)
e_{min}	minimum wall thickness (at any point)
e_n	nominal wall thickness
$\bar{\sigma}_{LPL}$	lower predicted limit
$\bar{\sigma}_s$	design stress
T_{min}	minimum butt joint fusion temperature
T_{max}	maximum butt joint fusion temperature
P_c	critical pressure
P_{CFs}	critical pressure measured in full-scale test, BS EN ISO 13478
P_{Cs4}	critical pressure measured in S4 test, BS EN ISO 13477

3.9 Abbreviations

BRT	batch release testing
DN	nominal size
DN/OD:	nominal size outside diameter related
LPL	lower predicted limit
MFR	melt mass-flow rate
MOP	maximum operating pressure
MRS	minimum required strength
PVT	process verification testing
RCP	rapid crack propagation
SDR	standard dimension ratio
TT	type testing

4. Conformance

4.1 Units of measurement

In this standard, for data expressed in both SI and USC units, a dot (on the line) is used as the decimal separator, and no comma or space is used as the thousands separator, in order to be consistent with other Gas Transporter specifications.

5. Material

5.1 The polyethylene gas pipe systems shall be suitable for carrying gaseous fuels and in particular natural gas having a composition specified in BS EN ISO 13686 or suitable manufactured gases.

5.2 The pipes shall be made from virgin material or manufacturer's own clean rework (reprocessible) compound or a blend of both, and shall be from the identical polyethylene base compound.

The compound from which the pipes are made, including each layer for multilayer pipes, shall conform to GIS/PL2-1 and be classified PE100.

Clean rework (reprocessible) material, generated from a manufacturer's own production of pipe to this standard, may be used provided it has not left the manufacturer's premises (re-grinding and pelletisation may be done outside the manufacturer's premises provided it is under the manufacturer's supervision).

Pipe produced from rework (reprocessible) material shall be identifiable and/or traceable throughout the manufacturer's production records.

Pipe produced from any rework (reprocessible) compound, including from multilayer pipes shall be Type Approval Tested in accordance with the requirements of Annex F of this standard. Testing pipes produced from 100% rework is viewed as "worst case", thus Annex F approves any blend of virgin compound & rework (reprocessible) compound, from 1% to 100%. All PE compounds used for rework (reprocessible) shall be from European sources and of grades with a previous supply history to the UK Gas Industry.

6. Compound

Compounds received from the compound manufacturers shall be tested in accordance with Table 1.

NOTE: The requirements are based upon tests in GIS/PL2-1, which have been conducted previously by the compound manufacturers.

7. General

7.1 Appearance

When viewed without magnification, the internal and external surfaces of pipes shall be smooth and clean and shall have no scoring, cavities and other surface defects to an extent that would prevent conformity to this standard.

The ends of the pipe shall be cut cleanly and square to the axis of the pipe.

7.2 Colour

Pipes shall be coloured orange (see GIS/PL2-1).

The inner layer of co-extruded Multilayer PE pipes shall be black with an orange external layer (see GIS/PL2-1).

Note: there shall be no stripes on the outer layer

7.3 Pipe Construction

Pipes may be constructed of:

- Orange PE100 pipe (32-630mm SDR11)
- Black PE100 inner layer with co-extruded PE100 orange outer layer (32 - 630mm SDR11)

Table 1 - Compound properties

Properties	Sampling frequency ^a	Requirements ^b	Test method ^b
Compound density	Per Compound Batch	Maximum deviation ± 3 kg/m ³ of nominated value of compound. (Density of compound declared by compound manufacture)	Designated compound for pipe extrusion (BS EN ISO 1872-1). Method BS EN ISO 1183-1, -2 and -3
Melt flow rate (MFR)	Per Compound Batch	Max Deviation ± 20 % of nominated value (MFR of compound declared by compound manufacturer) ^c	BS EN ISO 1133 (Condition T)
OIT	Per Compound Batch	>20 min at 200 °C	BS EN ISO 11357-6
Pellet geometry	Per Compound Batch	Compare with sample from compound manufacturer	—

^a) Minimum sampling frequency.

^b) Detailed test requirements and methods are given in GIS/PL2-1.

^c) The acceptable MFR range depends on pipes being able to make butt fusion joints with a bead shape and size that meets the requirements of the gas transporter as these beads are used in the field for butt joint quality control.

8. Geometry

8.1 Measurement of dimensions

Dimensions shall be measured in accordance with BS EN ISO 3126 at 23 °C \pm 2 °C, after being conditioned for at least 6 h. The minimum conditioning period, depending on wall thickness, shall be in accordance with Table 2.

In case of dispute, measurements shall be made not less than 24 h after manufacture.

Table 2 - Minimum conditioning period

Minimum wall thickness mm	Minimum conditioning period hours			
	In air at 23°C ($\pm 2^\circ\text{C}$)	In liquid at 20 °C ($\pm 1^\circ\text{C}$)	In liquid at 80 °C ($\pm 2^\circ\text{C}$)	In liquid at 80 °C ($\pm 2^\circ\text{C}$) ^a
≤ 12	6	1	6	3 ^a
>12 and ≤ 25	10	2	10	5 ^a
>25 and ≤ 60	24	3	24	12 ^a

^a) These conditioning times in liquid at 80 °C shall apply only if the specimen, instead of being cold-filled with liquid, is initially pre-filled with liquid at the same temperature as the hot tank.

8.2 Mean outside diameters, wall thicknesses and tolerances

The mean outside diameters of the pipe, demand wall thicknesses, shall conform to Table 3.

Table 3 -Outside diameter and wall thicknesses of standard polyethylene pipe (SDR11)

Dimensions in millimetres				
Nominal outside diameter, d_n	Mean outside diameter, d_{em}		Wall thickness, e	
	Min.	Max.	Min.	Max.
16 ^a	16	16.3	2.3	2.7
20 ^a	20	20.3	2.3	2.7
25	25	25.3	2.3	2.7
32	32	32.3	3.0	3.4
40	40	40.4	3.7	4.2
50	50	50.4	4.6	5.2
55	55	55.4	5.1	5.8
63	63	63.4	5.8	6.5
75	75	75.5	6.8	7.6
90	90	90.6	8.2	9.2
110	110	110.7	10.0	11.1
125	125	125.8	11.4	12.7
140	140	140.9	12.7	14.1
180	180	181.1	16.4	18.2
200	200	201.2	18.2	20.2
250	250	251.5	22.7	25.1
280	280	281.7	25.4	28.1
315	315	316.9	28.6	31.6
355	355	357.2	32.3	35.7
400	400	402.4	36.4	40.2
450	450	452.7	40.9	45.1
500	500	503.0	45.5	50.2
560	560	563.4	50.9	56.1
630	630	633.8	57.3	63.2
^{a)} For pipe sizes 16 mm and 20 mm, the actual values are SDR7 and SDR9 respectively due to minimum wall thickness considerations.				

8.3 Loss of roundness (flats)

The pipe shall not show any loss of roundness (i.e. flats) for more than $0.05d_n$ around the circumference of the pipe. At the point of maximum loss of roundness, the true diameter at that point shall not be less than the minimum value specified in Table 3.

8.4 Ovality

8.4.1 Straight pipe (all sizes)

For straight pipes, the maximum ovality shall conform to Table 4.

Table 4- Maximum ovality

Dimensions in millimetres		
Form	Nominal outside diameter, d_n	Maximum ovality
Straight pipe	≤ 75	$1 + 0.008d_n$
	>75 to ≤ 250	$0.02d_n$
	>250	$0.025d_n$
Coiled pipe	≤ 180	$0.06d_n$

8.4.2 Type testing: coiled pipe ovality (16 mm to 180 mm)

8.4.2.1 Ovality

The maximum ovality measured from the test section shall not exceed the applicable limit specified in Table 4.

8.4.2.2 Specimen preparation

For type testing (TT), coiled or drummed pipe (50 m minimum length) shall be stored at ambient temperature for seven days prior to testing. The winding temperature at the time of coiling of each size and SDR shall be recorded and shall not exceed 35 °C, see Table 5.

8.4.2.3 Procedure

Immediately after unwinding, cut a 1 m long section 20 m from the pipe end of the innermost layer. Condition the test section at 23 °C \pm 2 °C for 1 h and then measure the ovality.

8.4.3 Batch release testing: coiled pipe ovality (≥ 90 mm)

8.4.3.1 Ovality

The maximum ovality measured from the test section shall not exceed the applicable limit given in Table 4.

8.4.3.2 Procedure

For batch release testing (BRT) either:

- a) measure the ovality of 90 mm pipes and above (approximately 10 m from the pipe end) annually on each size and SDR produced, provided the winding temperatures during production do not exceed the winding temperatures measured during type testing; or
- b) measure ovality on every five hundredth coil/drum of each size and SDR produced.

NOTE Ovality: BRT of coiled pipe sizes less than 90 mm is not required.

8.5 Dimensions of pipe coils

Coiled pipe shall be deemed acceptable provided that the dimensions of the coil are in accordance with Table 5 and that the maximum surface temperature of the pipe during coiling conforms to Table 5.

The width of any coil shall be not greater than 1 m, and all coils shall be labelled in accordance with 15.4.

Table 5 - Coil dimensions and winding temperatures (SDR11)

Nominal outside diameter, d_n mm	Minimum internal coil diameter m	Maximum external coil diameter m
16 ^a	0.6	4.0
20 ^a	0.6	4.0
25	0.6	4.0
32	0.7	4.0
40	1.0	4.0
50	1.0	4.0
55	1.3	4.0
63	1.3	4.0
75	1.5	4.0
90	1.8	4.0
110	2.0	4.0
125	2.5	4.0
140	2.5	4.0
180	3.0	4.0
Note Maximum external coil temperature at time of winding shall be 35 °C. ^a) For pipe sizes 16 mm and 20 mm, the actual values are SDR7 and SDR9 respectively, due to minimum wall thickness considerations.		

8.6 Circumferential reversion

The circumferential reversion of pipes with a d_n equal to or greater than 180 mm shall be determined after conditioning in water at 80 °C in accordance with BS EN ISO 1167. The pipe test pieces shall be a minimum of $3d_n$ in length. With the test piece at 23 °C \pm 2 °C, circumferential measurement shall be made to establish dem.

The difference between the d_{em} measurement made at distance of $1.0d_n$ and $0.1d_n$ respectively from the end of the test piece shall not be greater than the d_{em} tolerance range specified in Table 3.

9. Mechanical properties

9.1 Conditioning

Unless otherwise specified by the applicable test method, the test pieces shall be conditioned at 23 °C \pm 2 °C in accordance with Table 2, before testing in accordance with Table 6.

9.2 Performance

When tested in accordance with the test methods specified in Table 6, the pipe shall conform to the performance requirements specified in Table 6 for each compound.

Table 6 - Mechanical properties

Properties	Performance requirements	Test parameters		Test method
		Parameter	Value	
Long-term hydrostatic strength ^a 20 °C	No failure during the test period of any test piece	End caps	Type a	BS EN ISO 1167
		Conditioning time	Shall conform to BS EN ISO 1167	
		Type of test	Water-in-water	
		Circumferential (hoop) stress for PE100	Stress taken from the appropriate regression curve ^a	
		No. of test pieces ^b	3 + 3	
		Test periods	100 h and 5000 h	
		Test temperature	20 °C	
80 °C Hydrostatic strength $d_n < 63$ mm (un-notched)	No failure during the test period of any test piece ^c	End caps	Type a	BS EN ISO 1167
		Conditioning time	Shall conform to BS EN ISO 1167	
		No. of test pieces ^b	3	
		Type of test	Water-in-water	
		Test pressure (PE100)	Select from Table 7 ^c	
		Test period	Select from Table 7 ^c	
		Test temperature	80 °C	
80 °C Hydrostatic strength after squeeze off. Sizes ≤ 250 mm	Squeeze off pipe to conditions in BS EN 12106 except using squeeze-off equipment to GIS/PL2-7	Test temperature	0 °C	BS EN 12106 GIS/PL2-7
		No. of test pieces ^b	2	
80 °C Hydrostatic strength after offset butt fusion. Sizes ≥ 90 mm	Produce butt weld to conditions in Annex A	No. of test pieces ^b	2	Annex A
		No failure during the test period of any test piece ^c	As above for 80 °C hydrostatic strength	As above for 80 °C hydrostatic strength
Yield strength and elongation at break ^{d, e}	PE100 Yield strength ≥ 20 MPa Elongation ≥ 500 %	Speed of testing: $e < 13$ mm $e \geq 13$ mm	100 mm/min 25 mm/min	BS EN ISO 6259-1 and BS EN ISO 6259-3
		Test piece dimensions	Shall conform to BS EN ISO 6259-3 ^f	
		No. of test pieces ^b	Shall conform to BS EN ISO 6259-1	
Resistance to slow crack growth $d_n \geq 63$ mm Notch pipe test	No failure during the test period ^c	Test temperature	80 °C	BS EN ISO 13479
		Test pressure (PE100)	Select from Table 8 ^c	
		Test period	Select from Table 8 ^c	
		Type of test	Water-in-water	
		Number of test pieces ^b	Shall conform to BS EN ISO 13479	

(Table 6 continued overleaf)

Table 6 — Mechanical properties (continued)

Properties	Performance requirements	Test parameters		Test method
		Parameter	Value	
Resistance to rapid crack propagation (RCP). $e \geq 15$ mm Critical pressure, P_c ^g	$P_{cFS} \geq 2.0$ MOP ^h with $P_{cFS} = 3.6 P_{cS4} + 2.6$ ⁱ	Test temperature	0 °C	BS EN ISO 13477 or BS EN ISO 13478
		Number of test pieces ^b	Shall conform to BS EN ISO 13477 or BS EN ISO 13478	
Integrity of the structure after deflection (multilayer pipes only) _j	$\geq 80\%$ of the initial stiffness value	Deflection	30% of d_{em}	BS EN ISO 9969 & BS EN ISO 13968
		Position of test piece	At 0°, 120° and 240° from the upper plate	

Table 6 Notes

- a) Tests at 100 h and 5000 h shall be conducted on non-weathered pipes, and tests at 1000hrs shall be conducted on weathered pipes. From the material classification in GIS/PL2-1, the 20 °C long-term hydrostatic tests shall be conducted using the appropriate hoop stresses obtained from the lower predicted limit applicable to 100 h, 1000 h, and 5000 h. For mature / approved UK suppliers and at the gas transporters discretion, new suppliers using European approved resins with a proven track record (at the discretion of the gas transporter) of supply to gas transporters within the European Commission may substitute the 5000 h test period by a test for 100 h. Approved European resins to include those manufactured outside of Europe.
- b) The numbers of test pieces given indicate the numbers required to establish a value for the characteristic described in the table.
- c) Only brittle failures shall be taken into account. If a ductile failure occurs, the test shall be repeated at the reference time of 1 000 h. The pressures and the associated test periods shall be selected from Table 7 or Table 8(as appropriate) or from a line based on the pressure/time points.
- d) Where the rupture takes place outside the gauge marks, the test is accepted if the value conforms to the requirements.
- e) The test can be terminated when the requirement is met, without necessarily carrying out the test up to the rupture of the test piece.
- f) Where practical, machined type 2 test pieces may be used for pipe wall thickness less or equal to 25 mm.
- g) Test pipes shall have a wall thickness of 15 mm or greater and shall be produced under commercial extrusion conditions.
- h) The maximum operating pressures (MOP) are given in Annex E. The MOP of orange PE100 SDR11 pipes of all sizes is 7 bar for the range 0° to 40 °C.
- i) Details of the full scale and S4 RCP testing procedures and requirements for PE100 orange pipes given in Annex D, with further information in Annex G. If the requirement is not met or S4 test equipment not available, then (re)testing by using the full-scale test shall be performed in accordance with BS EN ISO 13478 in which case the full-scale test takes preference. In this case: $P_c = P_{cFS}$.
- j) The following procedure to be applied:
- determine the initial ring stiffness of the pipe according to BS EN ISO 9969;
 - carry out the ring flexibility test according to BS EN ISO 13968;
 - after a 1h period for recovery, determine again the ring stiffness of the pipe according to BS EN ISO 9969;
 - the ring stiffness of the multilayer pipes shall be a least 80% of the initial ring stiffness.

Table 7- 80°C hydrostatic strength (un-notched). Test pressures at 80 °C and associated test periods for PE100, SDR11 pipes

Stress MPa	Pressure Bar	Time h
5.4	10.8	165
5.3	10.6	256
5.2	10.4	399
5.1	10.2	629
5.0	10.0	1 000

Table 8 - Resistance to slow crack growth (notched pipe test). Test pressures at 80 °C and associated test periods for PE100, SDR11 pipes (dn ≥ 63 mm)

Stress MPa	Pressure bar	Time h
4.5	9.0	165
4.4	8.8	233
4.3	8.6	331
4.2	8.4	474
4.1	8.2	685
4.0	8.0	1 000

10. Physical properties

10.1 Conditioning

Unless otherwise specified by the applicable test method, the test pieces shall be conditioned at 23 °C ± 2 °C in accordance with Table 2, before testing in accordance with Table 9.

10.2 Performance

When tested in accordance with the test methods specified in Table 9, the pipe shall conform to the performance requirements specified in Table 9.

Table 9 - Physical properties

Properties	Performance requirements	Test parameters		Test method
		Parameter	Value	
Oxidation induction time (OIT) (Thermal stability)	> 20 min	Test temperature	200 °C ^a	BS EN ISO 11357-6
		No. of test pieces ^{b, c}	3	
Electrofusion joint fusibility. Assemble joints to Annex B. Decohesive resistance (Peel test)	>66.7% ductile failure	Test temperature	23°C	Annex B
		No. of test pieces ^b	2	BS ISO 13954 ^d
Melt mass-flow rate (MFR)	After processing maximum deviation of ±20 % of the value measured on the batch used to manufacture the pipe	Loading mass	5 kg	BS EN ISO 1133
		Test temperature	190 °C	
		Time	10 min	
		No. of test pieces ^b	Shall conform to BS EN ISO 1133	
Longitudinal reversion	≤ 3% Original appearance of the pipe shall remain	Test temperature	110 °C	BS EN ISO 2505
		Length of test piece	200 mm	
		Immersion time	1 h	
		No. of test pieces ^b	Shall conform to BS EN ISO 2505	
Crushing decohesion test for polyethylene (PE) electrofusion assemblies	Percentage brittle-failure decohesion shall be equal to or less than the value stated in the relevant product standard	Test temperature	6 h at 23°C ±2°C	BS ISO 13955
		Minimum no Test Pieces	3	
		Time	6h after removal	
<p>^a) Test may be carried out at 210 °C providing that there is a clear correlation with the results at 200 °C. In case of dispute the reference temperature shall be 200 °C.</p> <p>^b) The numbers of test pieces given indicate the numbers required to establish a value for the property described in the table.</p> <p>^c) Samples shall be taken from the outer and inner pipe surfaces as well as from mid wall position.</p> <p>^d) BS ISO 13954 requires that each sample be cut into 4 test pieces for measurement.</p>				

11. Butt fusion jointing compatibility: fitness-for-purpose

11.1 General

Polyethylene pipes intended to be used for jointing by butt fusion shall be prepared and assembled in accordance with BS ISO 11414 except using butt welding procedures and butt fusion equipment in accordance with GIS/PL2-3. Joints shall be assessed for fitness-for-purpose under normal conditions in accordance with 11.2.

Manufacturers making more than one pipe grade but of the same classification or substituting a new grade for an old one of the same classification, shall conduct the compatibility tests in accordance with 11.2, on all the possible pipe combinations between the same grades.

11.2 Normal conditions (23 °C)

For the assessment of fitness-for-purpose under normal conditions, butt fusion joints shall be produced between pipes of the same material grade at an ambient temperature of 23 °C ± 2 °C, using the parameters specified in BS ISO 11414, Annex A except using butt welding procedures

and butt fusion equipment in accordance with GIS/PL2-3.

The tensile strength and 80 °C hydrostatic strength (un-notched) of butt joints shall conform to Table 10.

Table 10 - Fitness-for-purpose properties of the butt joint

Properties	Performance requirements	Test parameters		Test method
		Parameter	Value	
80 °C hydrostatic strength. (un-notched)	No failure during the test period of any test piece ^a	End caps	Type a	BS EN ISO 1167
		Conditioning time	Shall conform to BS EN ISO 1167	
		No. of test pieces ^b	3	
		Type of test	Water-in-water	
		Circumferential (hoop) stress for:		
		PE100& PE100/PE100	Select from Table 7 ^a	
		Test period	Select from Table 7 ^a	
		Test temperature	80 °C	
Tensile strength for butt fusion	Test to failure - ductile: pass brittle: failure	Speed of testing	5 mm/min	BS ISO 13953
		Test temperature	23 °C	
		No. of test pieces ^b	Shall conform to BS ISO 13953	
^a) Only brittle failures are to be taken into account. If a ductile failure occurs, the test may be repeated at a lower pressure in Table 7. The pressures and the associated test periods shall be selected from Table 7 or from a line based on the pressure/time points.				
^b) The numbers of test pieces given indicate the numbers required to establish a value for the characteristic described in the table.				

12. Maximum operating pressure, overall service (design) coefficient, and design stress.

The minimum value of the overall service (design) coefficient, C, for pipes to this specification for the supply of gaseous fuels shall be 2.9. The maximum value for the design stress, σ_S , shall be 3.5 MPa for PE100 compound, which has a minimum required strength (MRS) of 10.0MPa.

The maximum operating pressure (MOP), over the range 0° to 40 °C, is 7 bar for all orange PE100 and multilayer PE100/PE100 pipe sizes. PE100 and multilayer PE100/PE100 pipes shall not be operated below 0 °C.

The full-scale critical pressures shall be determined at 0 °C and they shall be greater than 14 bar, i.e. 2.0 times the MOPs (see Annex D).

where:

$$\sigma_S = \frac{MRS}{C}, \text{ MPa}$$

$$MOP = \frac{20 \times MRS}{C \times (SDR - 1)} = \frac{20 \sigma_S}{(SDR - 1)}, \text{ bar}$$

13. Type testing of pipe

13.1 General

The test programme in accordance with Table 11 shall be carried out on each size of pipe, except where a range of pipe sizes in a size group permits a reduced number of test sizes (see 13.2).

Pipes, when tested in accordance with Table 11, shall conform to the performance requirements specified in Table 11.

NOTE: Users of this standard are advised to consider the desirability of third-party certification of product conformity with this standard or testing by an independent laboratory accredited to BS EN ISO/IEC 17025.

Table 11 - Properties of pipes that require type testing (TT) per compound

Properties		Shall conform to:	Sampling procedure ^a	No. of test pieces ^b	No. of measurements per test piece
Appearance		7.1	Two diameters/ size group	1	1
Colour		7.2	Two diameters/ size group	1	1
Geometrical properties	d_{em}, e	8.2	Two diameters/ size group	2	1 + 1
	Ovality	8.4	Two diameters/ size group	2	1
	Dimensions of pipe coils	8.5	All sizes	1	1
	Circumferential reversion	8.6	Two diameters/ size group	2	1
Mechanical properties (non-weathered pipes)	20 °C Long-term hydrostatic strength 100 h and 5000 h	9.2	Two diameters/ size group	3 + 3	1
	80 °C Hydrostatic strength $d_n < 63$ mm (un-notched)	9.2	One diameter/ size group	3	1
	80 °C Hydrostatic strength after squeeze-off $d_n \leq 250$ mm	9.2	Two diameters/ size group	2 ^a	1
	80 °C Hydrostatic strength after offset butt fusion $d_n \geq 90$ mm	9.2	Two diameters/ size group	2 ^a	1
	Yield strength and elongation at break	9.2	Two diameters/ size group	Shall conform to BS EN ISO 6259-1	1
	Resistance to slow crack growth $d_n \geq 63$ mm Notch pipe test	9.2	Two diameters/ size group	3	1
	Resistance to rapid crack propagation ^{c, d} (RCP) $e \geq 15$ mm Critical pressure, P_c	9.2	Test at 0 °C: Maximum pipe size and maximum wall thickness of that size in the manufacturer's range	Shall conform to BS EN ISO 13477 or BS EN ISO 13478	Shall conform to BS EN ISO 13477 or BS EN ISO 13478
	Integrity of the structure after deflection (multilayer extruded pipes only)	9.2	Two diameters/ size group	2	1

Table 11 — Properties of pipes that require type testing (TT) per compound (continued)

Properties		Shall conform to:	Sampling procedure ^a	No. of test pieces ^b	No. of measurements per test piece	
Physical properties	De-cohesion of an electrofusion joint	10.2	Two diameters/ size group	3	4	
	Melt mass-flow rate (MFR)	10.2	Two diameters/ size group	3	1	
	Longitudinal reversion	10.2	Two diameters/ size group	1	1	
Strength of butt joint	Normal condition	Tensile strength ductility	11.2	Two diameters/ size groups 2 and 3 only.	1	Shall conform to BS ISO 13953
Marking	15	Two diameters/ size group	1	1		

^a) Evenly distributed diameters over the product range shall be chosen, except Squeeze off and Offset Butt Joint, where the largest size shall be tested in the manufacturers' product range. The product range in each size group shall be defined by the manufacturer.

Samples shall comprise the smallest and largest diameter of the range manufactured.

Where a manufacturer extends his production beyond his approval, additional relevant type testing shall be carried out.

^b) The number of test pieces given in the table shall be the minimum. All test pieces shall pass the relevant test(s).

^c) If RCP test(s) are successful, approval shall be given to any smaller pipe sizes.

^d) If necessary, reducing the S4 test temperature in order to achieve the correct initiation conditions of a crack length of $1d_n$ with zero pressure is acceptable. The RCP test shall then be conducted at this lower temperature with the normal $P_{c,S4}$ test pressure of 3.2 bar.

NOTE: Test pieces for tests relating to geometrical characteristics may be subsequently used in the destructive tests listed in this table.

13.2 Selection of test pipe sizes: size grouping

Pipe size groups shall be in accordance with Table 12.

Table 12 - Size groups for pipes

Size group	Dimensions in millimetres		
	1	2	3
Nominal outside diameter, d_n , for pipes	$d_n < 75$	$75 \leq d_n < 250$	$250 \leq d_n \leq 630$

The manufacturer shall define the product range in each size group and choose for testing evenly distributed diameters over the product range. Samples shall comprise of the smallest and largest of the range manufactured.

Where a manufacturer extends his production beyond his approval, additional relevant type testing shall be carried out.

14. Batch release testing

The pipe manufacturer shall carry out a schedule of batch release testing (BRT) during production in accordance with Table 13.

Table 13 - Properties and minimum sampling frequencies for BRT

Properties		Shall conform to:	Minimum sampling frequency per extruder	Number of samples ^a	Number of measurements per sample
Appearance		7.1	Every 4 h	1	1
Colour		7.2	Every 6 months	1	1
Geometrical properties	Outside diameter	8.1, 8.2	Continuously or every 4 h	1	1
	Wall thickness ^b	8.1, 8.2		1	1
	Ovality	8.4	Daily	1	1
	Loss of roundness (flats)	8.3	Daily	1	1
	Circumferential reversion	8.6	Daily	1	1
Mechanical properties	80°C Hydrostatic strength $d_n < 63$ mm (un-notched)	9.2	One sample/size/week	1	1
	Yield strength and elongation at break	9.2	One sample/size/week	Shall conform to BS EN ISO 6259-1	1
	Resistance to slow crack growth $d_n \geq 63$ mm Notch pipe test	9.2	One sample/size/week	1	1
	Rapid crack propagation resistance (RCP) $d_n \geq 250$ mm ^c S4 or [full scale]	9.2	One sample/year	3 [1]	3 [1]
Physical properties	Oxidation induction time (thermal stability)	10.2	One sample/size/week	1	1 (inside surface only)
	Melt mass-flow rate (MFR)	10.2	Weekly	1	1
Marking		15	Every 4 h	1	1
a) The number of test pieces given in the table shall be the minimum. All test pieces shall pass the relevant test(s).					
b) Continuous wall thickness monitoring shall also be used.					
c) The test pipe shall be 250 mm SDR11 or larger. Three samples for S4 test or one full-scale test.					
NOTE 1 Minimum frequency of sampling shall be as follows. Continuously: on-line monitoring of pipe dimensions. Every 4 h: one sample at the start of production then every 4 h. One sample/size/week: one sample at the start of production of each size then repeated every week.					
NOTE 2 Ovality BRT of coiled pipe in sizes less than 90 mm is not required.					

15. Marking

15.1 General

The marking elements shall be printed or formed directly on the pipe in such a way that after storage, weathering, handling and installation, legibility is maintained during the use of the pipe.

Marking shall not initiate cracks or other types of defects, which adversely influence the performance of the pipe.

15.2 Mark colour and size

All pipes shall be permanently and legibly marked along their length with a legend, which shall be indented to a depth of between 0.02 mm and 0.15 mm.

Pipe not greater than 75mm nominal size shall be marked with a single “non-inked” indented strip, plus an inkjet print line. Larger pipe sizes shall be marked with two “non-inked” indented strips on opposite sides of the pipe, plus an inkjet print line.

The height of the characters shall be uniform and at least the following:

- a) 3 mm for pipe 90 mm nominal size or less;
- b) 5 mm for pipe greater than 90 mm nominal size.

15.3 Minimum required marking

Pipe conforming to GIS/PL2-8 ²⁾ shall be permanently marked at 1 m intervals in accordance with Table 14 and where authorized, the product conformity mark of a third party certification body, e.g. BSI Kite-mark.

NOTE: Attention is drawn to the advantages of using third party certification of conformance to a standard.

15.4 Contractor Alternative marking method

A contractor may submit an alternative method of marking to the gas transporter for approval. The proposed method of marking shall not prevent compliance to the requirements of this standard.

2) Marking GIS/PL2-8 on or in relation to a product represents a manufacturer's declaration of conformity, i.e. a claim by or on behalf of the manufacturer that the product meets the requirements of the standard. The accuracy of the claim is therefore solely the responsibility of the person making the claim. Such a declaration is not to be confused with third party certification of conformity, which may also be desirable.

Table 14 - Minimum required marking

Legend	Mark or symbol examples
Number and date of this pipe standard	GIS/PL2-8: 2021
The name or trademark of the manufacturer or their appointed agent	Name or symbol
For pipes $d_n \leq 32$ mm: Nominal outside diameter x nominal wall thickness ($d_n \times e_n$)	32 × 3.0
For pipes $d_n > 32$ mm: –nominal outside diameter, d_n ; –SDR.	200 or 200 mm SDR11
Material and designation	PE100 or PE100/PE100 for multilayer pipes
Manufacturer's traceability: Production site Extrusion line Date of manufacture	DD/MM/YY
Internal fluid	GAS
Weight per metre for $d_n \geq 125$ mm	20 kg/m
Sequential number in metres ^a	000 to 999
^{a)} The sequential number shall be required for coiled pipes and preferable for straight pipe.	

15.5 Marking of coils and drums

Each coil and drum of pipe shall be clearly and indelibly labelled in accordance with Table 15.

Table 15 - Marking of coils and drums ^a

Legend	Mark or symbol examples
Weight of coil or drum	50 kg
Length	100 m
Nominal outside diameter, d_n and SDR	180 mm SDR11
Start and finish sequential number in metres	050 – 150
^{a)} Drummed pipe shall not be banded, as both ends shall be secured to the drum.	

For pipe sizes equal to or greater than 90 mm, the label shall also carry the following warning:

“Before un-strapping, ensure that both pipe ends and coil/drum are firmly mechanically restrained.”

A label attached to the lead end of the pipe, or a directional arrow printed on the surface of the pipe, shall be used to define which end of the coiled pipe should be dispensed first.

15.6 Marking of pipe bundles

When straight pipe lengths are supplied in bundles, the manufacturer shall affix a label on both sides of the bundle indicating:

- a) weight (kg);
- b) correct orientation of the bundle (e.g. “THIS WAY UP”) to assist in the safe loading, unloading and stacking of the bundle.

16. Delivery conditions

The lengths of straight pipe shall be 6 m or 12 m, and coiled pipe shall be supplied in a minimum length of 50 m. The pipe shall not contain any swarf within the cut pipe.

If the lengths of individual pipes are specified, such lengths shall be not less than that specified when determined at $23\text{ °C} \pm 2\text{ °C}$.

Pipe supplied in coils or on drums shall be packaged in accordance with Annex C.

Annex - A **Method for jointing by offset butt fusion**

A.1 Principle

The adjacent ends of two longitudinally-aligned pipes are fused by contact with a heated plate and then jointed whilst subject to a specified amount of radial misalignment.

A.2 Apparatus

Apparatus shall conform to GIS/PL2-3.

A.3 Procedure

A.3.1 Hot plate temperature

Raise the temperature of the hot plate until it lies in the range 230 °C to 236 °C and maintain the temperature between those limits for 15 min before each joint is made.

A.3.2 Misalignment

Mount and axially align the two lengths of pipe to be joined in the butt fusion machine and then adjust the positions of the clamps to introduce a radial misalignment as follows:

- a) for pipes not greater than 180 mm nominal outside diameter, a minimum offset of 1 mm at any point around the circumference;
- b) for pipes greater than 180 mm nominal outside diameter, an offset of not less than 10 % of the wall thickness of the pipe.

NOTE The misalignment is applied to serve as a feature of the test condition. For installation purposes, misalignment should always be minimized and may be subject to a different limit.

A.3.3 Fusion

Using the butt fusion welding procedure specified in GIS/PL2-3, apply the mutually opposed ends to the heated plate and then to one another to form a fused butt joint.

A.3.4 Inspection

Inspect the joint and ensure that the bead conforms to the gas transporter's required shape and size, otherwise discard the jointed test piece and adjust the welding conditions or procedure within the prescribed limits until such a joint is obtained.

A.4 Test report

The test report of the jointing operation shall include the following:

- a) identification of the test pieces;
- b) reference to this standard, i.e. GIS/PL2-8;
- c) jointing procedure used;
- d) amount of offset obtained;
- e) date of jointing.

Annex - B Method for electrofusion socket joint de-cohesion (peel) strength (normative)**B.1 Principle**

The capability is required of the pipe to produce good electrofusion joints using the GIS/PL2 procedures.

It is also used to assess the ability of 100% reprocessible (rework) pipes to produce good electrofusion joints (see 5.2 & Annex F)

B.2 Test specimen preparation

The test specimen shall consist of two pipes, each of minimum length $5d_n$, fused to an approved electrofusion coupler in accordance with GIS/PL2-4. The test pipe shall be one size in the range 75mm to 250mm SDR11 for PE100.

B.3 Test procedure

Remove the surface of PE100 pipes to a depth up to 0.2mm using tooling in accordance with GIS/PL2-5, before conditioning and subsequent fusion.

Condition the pipes for 8 h at $-5^{\circ}\text{C} \pm 2^{\circ}\text{C}$, and condition the fitting for 8 h at $23^{\circ}\text{C} \pm 2^{\circ}\text{C}$.

Fuse the coupler to the pipes within the cold storage, or within 1 min of removal from the cold storage, at 39V for the manufacturers specified fusion time.

Test the specimen for de-cohesive resistance (peel test) in accordance with BS ISO 13954.

Annex - C **Packaging of coiled and drummed pipe (minimum requirements)** **(normative)**

C.1 General

All pipes shall be constrained in a stable configuration, to ensure the safe and controlled dispensing of the pipe without damage or kinks. Any exposed ends of pipes on coils or drums shall be suitably protected from damage (e.g. by means of end caps/plugs).

The maximum external surface temperature of the pipe at time of coiling shall not exceed 35°C. The temperature shall be measured using a contact thermometer probe or agreed alternative at a distance as near as practicable to the point where the pipe enters the coiler.

C.2 Coiled Pipe

C.2.1 General

The dimensions of the pipe coils shall be in accordance with 8.5, Table 5. The maximum width of any coil shall be 1m.

C.2.2 Pipe not greater than 32mm

Coiled pipe not greater than 32mm diameter shall be restrained using an outer covering of “shrink wrap” or equivalent material to enable pipe to be drawn from the centre of the coil.

C.2.3 Pipe greater than 32mm

Coiled pipe greater than 32mm in diameter shall be constrained in a stable configuration by applying a minimum of 2 bands per layer for pipes $\leq 125\text{mm}$, and 3 bands per layer for pipes $> 125\text{mm}$. The bands shall be equally spaced and staggered on each layer.

Each band shall have a minimum width of 12mm if manufactured from polypropylene material, and 50mm if adhesive tape is used. The breaking load of the banding or adhesive tape supplied as new, shall be > 1.5 Tonnes. It shall be possible to remove one layer of the coil without the remainder of the coil being unraveled, and individual layers shall be clearly discriminated by the banding.

For all pipe diameters $\geq 75\text{mm}$, 2 security bands shall be applied to the coil, (see Figure C.1) one to retain the inner tail and one to retain the outer tail. These shall be positioned no less than 2 pipe diameters, and no greater than 1metre, from each end. The security bands shall be a minimum of 12.5mm wide, and shall be either plastic coated steel, or steel covered in a protective sleeve.

Adhesive tape may be applied to the security bands to minimise slippage and maximise safety.

All banding/adhesive tape shall be sufficiently stable to minimise movement during transport and handling, and shall withstand normal handling loads and stresses.

The ends of the coil shall be nominally straight for a distance greater than two diameters, and both ends shall be free from anchorage holes. If necessary, re-rounding/straightening tools may be used.

For pipe sizes $\geq 90\text{mm}$, a label or tape shall also be applied carrying the following warning:

“Before un-strapping, ensure that both pipe ends and coil/drum are firmly mechanically restrained”

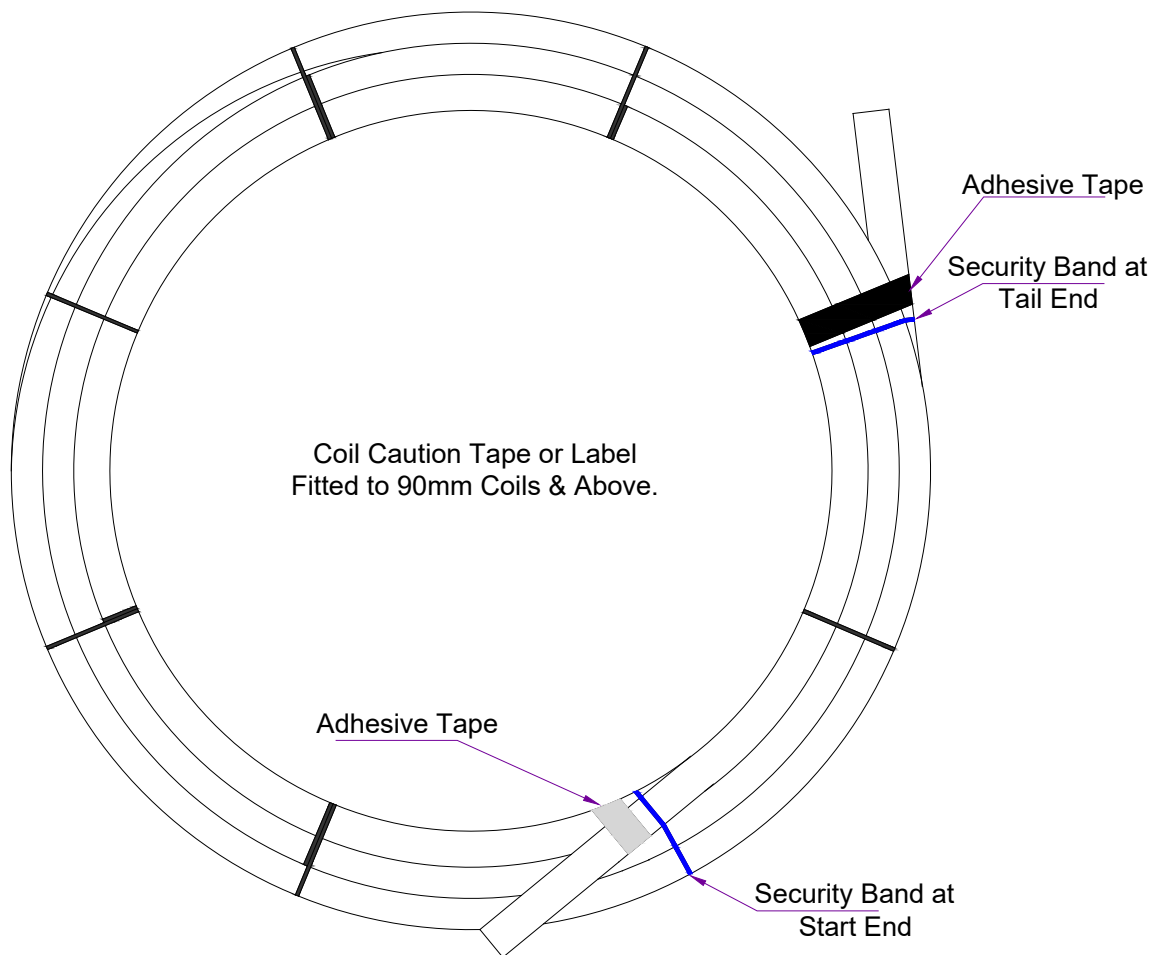

NOTE 1 : Banding of individual layers of coils should be in different positions and should be clearly staggered.

NOTE 2 : Position of Security Banding should be not less than 2 pipe diameters, and no greater than 1m from pipe lead and tail ends.

Figure C. 1 - Guide to the Banding of individual layers of polyethylene pipe
(Positions may be subject to variation)

C.2.4 Drummed pipe

The pipe shall be dispensed from a trailer or low loader.

Pipe shall be wound on to drums having the principal limiting dimensions as shown in Figure C.2. Drums shall be sufficiently robust to withstand normal site handling, and shall have a permanent indication of unladen weight. The polyethylene pipe shall not stand proud of the drum outer guard rail.

The weight of the drum plus maximum length of polyethylene pipe shall not exceed 2500 kg unless intended for direct use from a low loader; however, in this case the system shall incorporate a braking device. The pipe manufacturer shall declare the maximum length of pipe (for a given diameter and SDR) that is compatible with the drum weight and dimension criteria. Security Bands shall be steel.

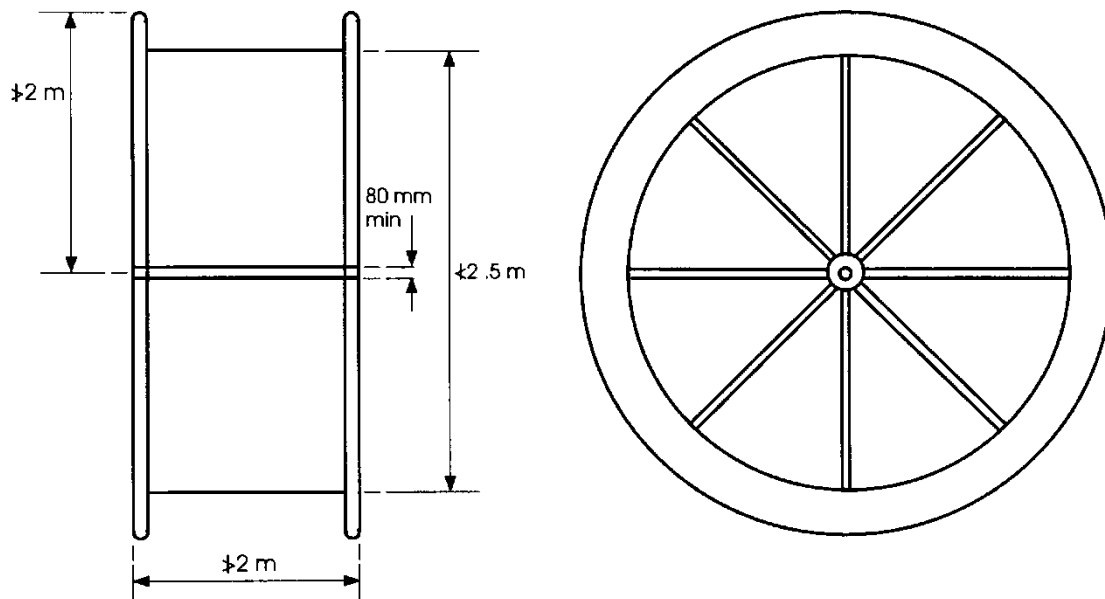

Distance from centre axis to outer rim : 2 m maximum
Outside width : 2 m maximum
Bore of axle : 80 mm minimum

Figure C. 2 - Principal limiting dimensions of drums

Annex - D RCP Testing Procedures for PE100 & PE100/PE100 multilayer orange Pipes (normative)

All PE100 orange pipes, including multilayer pipes, shall be able to operate at a MOP of 7 bar but only for temperatures of 0 °C and above (see Table E.1).

The correlation equation proposed by the ISO TC138/SC4 committee in producing BS EN ISO 13477 is: -

$$P_{FS} = 3.6P_{S4} + 2.6 \quad \text{bar} \quad (1)$$

Where

P_{FS} – full-scale pressure, bar

P_{S4} – S4 pressure, bar

For GIS/PL2 Part 8, the RCP test shall be conducted on the manufacturer's maximum pipe size, provided it has a wall thickness of 15mm or greater

A full-scale RCP test (BS EN ISO 13478) or an S4 RCP test (BS EN ISO 13477) shall be conducted.

The full-scale test shall be conducted at a temperature of 0°C and test pressure of 14 bar.

The S4 test shall be conducted at a maximum temperature of 0°C and a test pressure (P_{S4}) of 3.2 bar.

If the pipe fails the S4 test, it is permitted to re-test using the full-scale test, which if successful takes precedent, as the full-scale test is the reference test.

If successful, approval is given to any smaller pipe size, provided the wall thickness is not greater than that tested.

Annex - E Diameters and maximum operating pressures (MOP) for PE100 orange and Multilayer PE100/PE100 polyethylene pipes (normative)

Table E. 1- Diameters and maximum operating pressures for PE100 and multilayer PE100/PE100 polyethylene pipes

Pipe Outside Diameter mm	Maximum operating pressure bar
	Pipe (class) SDR 11
	0°C to 40°C
16	7
20	7
25	7
32	7
40	7
55	7
63	7
75	7
90	7
110	7
125	7
180	7
200	7
225	7
250	7
315	7
355	7
400	7
450	7
500	7
560	7
630	7
800	7
Notes The operating temperature range for the UK is in the range 0°C to 40°C.	

Annex - F Type Approval testing of Pipes produced from 100% rework (normative)

Pipes produced from a single grade of re-processable material conforming to the requirements in Clause 5.2 of this standard, shall be subject to Type Tests in Table F.1.

Table F. 1 - Type approval testing from 100% rework

Properties	Performance Requirements	Test Parameters	Test Method
Resistance to Slow Crack growth $\geq 63\text{mm}$ (Notched Pipe Test)	No failure during the test period	3 samples as defined in Table 6	BS EN ISO 13479
80°C Hydrostatic Strength after 10% Offset Butt fusion – Sizes $\geq 90\text{mm}$	Produce Butt Weld to conditions in Annex A No failure during the test period of any test piece.	3 samples as defined in Table 6	BS EN ISO 13479
Electrofusion joint assemblies - Fusibility at -5°C, Min Power. De-cohesive resistance (Peel Test)	Ductile over 66.7% of fusion length	3 fused assemblies.	Annex B BS ISO 13954
Yield Strength & Elongation at Break	PE100 Yield Stress / Elongation $\geq 20\text{MPa} / \geq 500\%$	1 set of tensile samples per pipe size	BS EN ISO 6259-1 & BS EN ISO 6259-3
OIT (Thermal Stability)	$>20\text{minutes}$ at 200°C	1 set of OIT samples (Outer, Mid, & Inner) per pipe size	BS EN 728
Resistance to Rapid Crack Propagation (RCP) S4 Small Scale Test $\geq 15\text{mm}$ Critical Pressure, P_c	Refer to Table 6 for details of performance requirements.	Test pipe size $\geq 180\text{mm}$ SDR11	BS EN ISO 13477
Integrity of the structure after deflection (multilayer extruded pipes only)	$\geq 80\%$ of the initial stiffness value	Deflection 30% of d_{em} Position of the test piece at 0°, 120° & 240°	BS EN ISO 9969 & BS EN ISO 13968
<p>Note: Where a range of pipe sizes is to be tested, the smallest and largest size in the range shall be tested as per the above table, except Rapid Crack Propagation where the minimum pipe size & SDR to be tested is shown. A successful RCP test shall approve smaller pipe diameters.</p>			

Annex - G **Rapid Crack Propagation (RCP) - Discussion and Requirements (informative)**

G.1 Summary

G.1.1 General

Rapid crack propagation (RCP) is the name used to describe a brittle crack travelling down a pipeline at very high speeds. RCP is more likely to occur with large diameter polyethylene (PE) pipes operating at high pressures and low temperatures when crack speeds of up to 1000 km/hr. (300 m/s) are produced. Consequently, the PE pipeline system has to be designed to ensure this failure mode cannot occur either during pressure testing or later in service.

The two RCP test methods – full-scale (BS EN ISO 13478) and S4 (BS EN ISO 13477) are described, together with the correlation between the test pressures derived from these two methods.

Conventional yellow PE80 pipes are operated at pressures up to 5.5 bar but the maximum operating pressures (MOP) are derated for larger pipe sizes and lower operating temperatures. They are operated down to -20 °C.

Peelable pipes have a yellow skin over a black or natural PE100 core. These are operated down to -20 °C at maximum operating pressures up to 2 bar for all sizes and temperatures.

PE80 black pipes with yellow stripes are to be operated up to 5.5 bar and at a temperature down to -20 °C, whereas PE100 black pipes (SDR21 & 26 only) with similar yellow stripes are to be operated up to 2 bar but only down to 0 °C.

Multilayer pipes have a yellow PE80 layer co-extruded over a black PE80 inner layer or a yellow PE80 layer co-extruded over a black PE100 inner layer. The black PE80 inner layer pipes are to be operated down to -20°C, whereas the black PE100 inner layer pipes (SDR21 & 26 only) are only operated down to 0 °C.

Conventional orange PE100 pipes are operated at pressures up to 7 bar but must always be operated at temperatures of 0 °C and above.

A multilayer pipe with black PE100 inner layer and an orange PE100 outer layer is also produced for up to 7 bar and at temperatures of 0 °C and above.

The detailed RCP testing requirements are given and discussed for Gas Industry Specifications: -

- GIS/PL2 Part 1 [General & PE compounds]
- GIS/PL2 Part 2 [yellow PE80, yellow striped, peelable and multilayer PE pipes]
- GIS/PL2 Part 8 [PE100 orange pipes and multilayer PE100/PE100 pipes]

The full-scale test at 0 °C and the appropriate pressure should be conducted. Alternatively, the S4 test may be used at the same or lower temperature but with the reduced test pressure calculated from the correlation equation (G.4.2). If the pipe fails the S4 test, it is permitted to re-test using the full-scale test, which if successful, takes precedence, as the full-scale test is the reference test.

G.1.2 PE80 yellow Pipes – Sizes 16 – 800mm at SDR 11, 13.6, 17.6, 21 & 26 at up to 5.5 bar

For GIS/PL2-1 compliance, the full-scale RCP test shall be conducted on one pipe size (wall thickness, $t \geq 15\text{mm}$) at 0 °C and a pressure of 2.0 x maximum operating pressure (MOP) for the appropriate pipe size and SDR and 0°C temperature.

For GIS/PL2 -2, the full-scale RCP test shall be conducted on the manufacturer's maximum pipe size ($t \geq 15\text{mm}$) at 0°C and a pressure of 2.0 x maximum operating pressure (MOP) for the appropriate pipe size and SDR and 0°C temperature. If successful, approval is also given to any smaller pipe size, provided the wall thickness is not greater than that tested.

In both cases, the S4 test method at 0 °C may be used instead and at the reduced test pressure calculated from the correlation equation (G.4.2).

G.1.3 Yellow Striped (black PE80) Pipes – Sizes 16 – 225mm at SDR11, 17.6, 21 & 26 at up to 5.5 bar

For GIS/PL2-1, the full-scale RCP test shall be conducted on one pipe size (wall thickness, $t \geq 15\text{mm}$) at 0°C and a pressure of 2 x maximum operating pressure (MOP) for the appropriate pipe size and SDR and 0°C temperature.

For GIS/PL2-2, the full-scale RCP test shall be conducted on the manufacturer's maximum pipe size ($t \geq 15\text{mm}$) at 0°C and a pressure of 2 x maximum operating pressure (MOP) for the appropriate pipe size and SDR and 0°C temperature. If successful, approval is also given to any smaller pipe size, provided the wall thickness is not greater than that tested.

In both cases, the S4 test method at 0°C may be used instead and at the reduced test pressure calculated from the correlation equation (G.4.2).

G.1.4 Yellow Striped (black PE100) Pipes – Sizes 225 – 800mm at SDR21 & 26 at up to 2bar

For GIS/PL2-1, the full-scale RCP test shall be conducted on one pipe size (wall thickness, $t \geq 15\text{mm}$) at 0°C and a pressure of 2 x maximum operating pressure (MOP) i.e. 14 bar for PE100 SDR11 pipe. For GIS/PL2-2, the full-scale RCP test shall be conducted on the manufacturer's maximum pipe size ($t \geq 15\text{mm}$) at 0°C and a pressure of 4 bar (2 x maximum operating pressure, MOP). If successful, approval is also given to any smaller pipe size, provided the wall thickness is not greater than that tested.

In both cases, the S4 test method at 0°C may be used instead and at the reduced test pressure calculated from the correlation equation (G.4.2) i.e. GIS/PL2-1 at 3.2 bar; GIS/PL2-2 at 0.4 bar.

G.1.5 Peelable Pipes (natural or black PE100 core) – Sizes 225 – 800mm at SDR 21 & 26 at up to 2 bar

For GIS/PL2-1, the full-scale RCP test shall be conducted on one pipe size ($t \geq 15\text{mm}$) **without the skin** at 0°C and a pressure of 2 x maximum operating pressure (MOP) for PE100 pipe i.e. 14 bar for PE100 SDR11 pipe.

For GIS/PL2 -2, the full-scale RCP test shall be conducted on 250 mm, 315 mm and the manufacturer's maximum pipe size at 0°C and a pressure of 4 bar (2x MOP). The skin is left intact. If successful, approval is given to any smaller and intermediate pipe sizes and further to any SDR26 pipe if the SDR21 pipe has RCP approval.

In both cases, the S4 test method may be used instead at maximum temperatures of 0°C and at the test pressure calculated from the correlation equation (G.4.2) i.e. GIS/PL2-1 at 3.2 bar; GIS/PL2-2 at 0.4 bar.

G.1.6 Multilayer Pipes (PE80 inner layer) – Sizes 16 – 225mm at SDR11, 17.6, 21 & 26 at up to 5.5 bar

For GIS/PL2-1 and the PE80 compound, the full-scale RCP test shall be conducted on one pipe size (wall thickness, $t \geq 15\text{mm}$) at 0°C and a pressure of 2 x maximum operating pressure (MOP) for the appropriate pipe size and SDR. and 0°C temperature.

For GIS/PL2-2, the full-scale RCP test shall be conducted on the manufacturer's maximum pipe size ($t \geq 15\text{mm}$) at 0°C and a pressure of 2 x MOP for the appropriate pipe size, SDR and 0°C temperature. If successful, approval is also given to any smaller pipe size, provided the wall thickness is not greater than that tested.

In both cases, the S4 test method may be used instead at maximum temperatures of 0°C and at the test pressure calculated from the correlation equation (G.4.2).

G.1.7 Multilayer Pipes (PE100 inner layer) – Sizes 225 – 800mm at SDR21 & 26 at up to 2 bar

For GIS/PL2-1 and the PE100 inner layer pipe, the full-scale RCP test shall be conducted on one pipe size ($t \geq 15\text{mm}$) at 0°C and a pressure of $2 \times \text{MOP}$ i.e. 14 bar for PE100 SDR11 pipe. .

For GIS/PL2-2, the full-scale RCP test shall be conducted on the manufacturer's maximum pipe size ($t \geq 15\text{mm}$) at 0°C and a pressure of 4 bar ($2 \times \text{MOP}$). If successful, approval is given to any smaller and intermediate pipe sizes and further to any SDR26 pipe if the SDR21 pipe has RCP approval.

In both cases, the S4 test method may be used instead at maximum temperatures of 0°C and at the test pressure calculated from the correlation equation (G.4.2) i.e. GIS/PL2-1 at 3.2 bar; GIS/PL2-2 at 0.4 bar.

G.1.8 PE100 orange Pipes or Multilayer PE100/PE100 pipes(32-630mm) –SDR11 at up to 7 bar

These pipes are made from PE100 only. They may be constructed entirely of orange PE100 or an inner layer of black PE100 and a coextruded orange PE100 outer layer.

For GIS/PL2-1, the full-scale RCP test shall be conducted on one pipe size ($t \geq 15\text{mm}$) at 0°C and a pressure of 14 bar ($2.0 \times \text{MOP}$) for each PE100 compound.

For GIS/PL2-8, the full-scale RCP test shall be conducted on the manufacturer's maximum pipe size ($t \geq 15\text{mm}$) at 0°C and a pressure of 14 bar ($2 \times \text{MOP}$). If successful, approval is also given to any smaller pipe size.

In both cases, the S4 test method may be used instead at a maximum temperature of 0°C and at the reduced test pressure of 3.2 bar calculated from the correlation equation (G.4.2).

G.2 Introduction

Rapid crack propagation (RCP) is the name used to describe a brittle crack travelling down a pipeline at very high speeds, Figure G.1. RCP is more likely to occur with large diameter polyethylene (PE) pipes operating at high pressures and low temperatures when crack speeds of up to 1000 km/hr. (300 m/s) are produced. Once RCP conditions are produced, then the whole section of the pipeline may be lost. It could occur without warning and the results could be catastrophic. Consequently, the PE pipeline system has to be designed to ensure this failure mode cannot occur either during air pressure testing (commissioning) at 1.5 times maximum operating pressure (MOP) or later in service, carrying gas.

The pipeline's maximum operating pressures (MOP) are given in GIS/PL2 Parts 1, 2 and 8 (Annex E).

G.3 RCP Initiation & Arrest

Even if the conditions for RCP are present in the PE pipeline, a high speed crack first has to be initiated in the pipe wall to produce RCP. Normally, PE is very tough and cracks are difficult to initiate under normal conditions. A high speed crack may initiate by impact by heavy machinery e.g. back-hoe excavator, particularly if the teeth or bucket are sharp, however, the most likely cause of initiation is the sudden brittle failure of a defective butt fusion joint. Under axial bending loads, the crack can initiate at one small part of the weld's circumference. The crack then rapidly travels around the weld interface, but as it does so, the hoop stress in the pipe wall (due to the internal pressure) deflects the circumferential high speed crack to run along the length of the pipe. Whether this axial high speed crack arrests within a few metres or continues to propagate depends entirely on the pipeline conditions.

Once RCP conditions are established the crack will continue to run down the pipeline as the pipe in front of the crack tip is under exactly the same conditions as the section it has just cracked. The high speed crack will propagate through any butt fusion joints. Naturally, the crack will be stopped by mechanical joints -at valves for example. It is believed that an electrofusion fitting will also stop the crack and although there is some evidence for this, it has not yet been demonstrated conclusively.

G.4 RCP Test Methods

G.4.1 Full-Scale Test

G.4.1.1 Normal Full-Scale Technique

Test methods have been developed to assess the resistance of plastic pipes to RCP and are described in detail in BS EN ISO 13478 (full-scale) (1) and BS EN ISO 13477 (S4) (2).

The full-scale method simulates what could happen in service by testing a long length of PE pipe at the expected minimum below ground temperature. From historical information, it is assumed that a temperature of 0 °C is reached below ground at the normal pipe burial depth of 750 mm once in every 50 years in the UK.

The test method requires that at least 14 m of PE pipe at 0 °C is be used for the test. This is connected to a steel pipe reservoir, at least 28 m long, to simulate a longer PE pipeline.



Figure G.1 RCP in 315 mm SDR 17.6 PE80 pipe

As the gas exhausts down the pipe during RCP, the crack tip generally lags behind the gas decompression wave front that spreads down the pipe (see Annex G.11). Consequently, the gas pressure at the crack tip, which is driving the crack forward, is less than the original pipe pressure.

Each full-scale test determines whether RCP will occur under the pipe's particular conditions

i.e. pressure, pipe size, temperature, etc. However, from a series of tests, the full-scale critical pressure (PcFS) between arrest and RCP under practical operating conditions can be measured at a temperature, normally of 0 °C. The critical pressure is conservatively taken as the highest arrest pressure; it is not an average of the highest arrest pressure and the lowest propagation pressure.

If the critical pressure for a particular pipe size is higher than that required by the gas utility, then all smaller diameter pipes of the same standard dimension ratio (SDR) will also be satisfactory. Smaller diameter pipes of the same SDR always have higher critical pressures.

Pipe Specifications GIS/PL2 Parts 2 & 8 require the crack to arrest at a full-scale test pressure of

2.0 x MOP.

G.4.1.2 Modifications to Full-Scale Test Technique for PE100 Pipes & Pipes with PE100 Inner Layers or Cores

The full-scale test method is also used for PE100 pipes, multilayer pipes with an inner PE100 layer or peelable pipes with PE100 cores, though the technique is usually slightly modified for these high RCP resistant PE100 pipes by first initiating a high-speed crack in a length of PE80 pipe before crossing a butt weld into the PE100 test section. The details are given in BS EN ISO 13478.

G.4.2 S4 Test Technique & Correlation Equation

A Small-Scale Steady-State (S4) laboratory test (BS EN ISO 13477) was developed as a cheaper and quicker alternative to the full-scale test method. The test uses pipe lengths of $7d_n$ (e.g. 1.75 m for 250 mm pipe), which are very much shorter than the 14 m (minimum) used in the full-scale tests. A system of internal baffles are also fitted inside the pipe bore that effectively stop axial gas exhaustion throughout the test, thus maintaining gas pressure at the crack tip at the initial test pressure, Annex G.11.

Again, the test measures the critical pressure (P_{cS4}) between arrest and RCP but, because of the higher crack tip pressure during the test, P_{cS4} will always be lower than the equivalent P_{cFS} . A correlation between the full-scale and S4 results is therefore necessary in order to enable the S4 results to be recalculated to an equivalent full-scale critical pressure. A correlating equation has been developed for PE materials, but in cases of dispute or when the S4 test is not available for the larger sizes, the full-scale test is recognised as the reference test.

The correlation equation proposed by the ISO TC138/SC4 committee in producing BS ISO 13477 (Annex G.11) is: -

$$P_{cFS} = 3.6P_{cS4} + 2.6 \text{ bar} \quad (1)$$

Any pressure in the S4 test can be converted the equivalent pressure in the full-scale test using the equation but it is generally used for converting the S4 critical pressure (P_{cS4}), derived from a series of S4 tests, to the equivalent full-scale critical pressure (P_{cFS}).

All decisions on the suitability of the PE pipe for operational use are based upon the full-scale pressure (P_{FS}) or the equivalent full-scale pressure recalculated from the S4 pressure (P_{S4}).

Pipe specifications GIS/PL2 Parts 1, 2 & 8 require the crack to arrest at a full-scale test pressure of 2.0 x MOP (see Annex E of main document). When the S4 test is used, the full-scale test pressure requirements in the specifications are back-calculated to the equivalent S4 test pressure before conducting the S4 test (G.4.2).

G.5 RCP Testing of PE80 Yellow Pipes and yellow striped PE80 Pipes

Specifications require PE80 yellow pipes and black PE80 pipes with yellow stripes to be able to operate at temperatures down to -20 °C, at pressures up to: -

5.5 bar for SDR11

4.0 bar for SDR 13.6

3 bar for SDR17.6

2 bar for SDR21 and SDR26

Due to RCP considerations, the MOPs of PE80 pipes in the larger sizes and lower temperatures have been reduced. The maximum operating pressures (MOP) are given in GIS/PL2 Parts 1, 2 & 8. Consequently, RCP tests are conducted at a "spot-check" temperature of 0 °C to ensure they have at least the same RCP resistance as the original PE80 pipes from which the de-rated MOPs were obtained. The full-scale test pressures are 2 x MOP. Alternatively, the S4 test at 0 °C can be used.

Note the test pressure (P_{S4}) that the pipe must pass in the S4 test is calculated from the BS/ISO/CEN correlation equation (G.4.2, equation 1) using 2 x MOP.

e.g. 250mm SDR11 PE80

Test Temperature = 0 °C

MOP = 4 bar (see Table B.1, GIS/PL2-2)

Therefore, $P_{FS} = 2.0 \times \text{MOP} = 8 \text{ bar}$

$$P_{S4} = \frac{(P_{FS} - 2.6)}{3.6} = 1.5 \text{ bar}$$

Consequently, the S4 test would have to demonstrate crack arrest at a minimum test pressure of 1.5 bar at 0 °C.

If the pipe fails the S4 test, it is permitted to re-test using the full-scale test, which if successful takes precedence, as the full-scale test is the reference test.

For GIS/PL2 Part 1, the RCP test has to be conducted by the compound manufacturer only on one pipe size, provided the wall thickness is 15 mm or greater.

For GIS/PL2 Part 2, the RCP test is conducted on the manufacturer's maximum pipe size ($\geq 15\text{mm}$). If successful, approval is given to any smaller pipe size, provided the wall thickness is not greater than that tested (see GIS/PL2 Part 2: Table 13).

Extracts from the detailed specification requirements from GIS/PL2-1, GIS/PL2-2 and GIS/PL2-8 are given in Annex G.12.

G.6 RCP Testing Peelable (PE100) Yellow Pipes

Gas Transporter specifications require all peelable pipes (SDR21 and SDR26) with a PE100 core to be able to operate at temperatures down to 0 °C and at operational pressures up to a MOP of 2 bar.

Consequently, the RCP test for all sizes must be conducted at 0°C. For all sizes, the full-scale test pressure will be 4 bar and for the S4 test, a pressure of 0.4bar. Either the full-scale or S4 test can be used. Again if the pipe fails the S4 test, it is permitted to re-test using the full-scale test, which if successful takes precedence, as the full-scale test is the reference test.

It has been observed that the grade of the polypropylene skin, its thickness and the adhesion to the PE100 core pipe, all have a complex effect on the RCP performance. Consequently, the polypropylene grade, thicknesses and adhesion levels (and tolerances where appropriate) need to be declared by the pipe manufacturer in seeking Type Testing approval. Modifications to the current GIS/PL2 Part 2 have been necessary, together with additional test method(s).

For GIS/PL2 Part 1, there are no RCP test requirements for peelable pipes because the skin has an effect on the results and this is controlled by the pipe manufacturer. However, it is still necessary to demonstrate the RCP performance of the PE100 core pipe ($\geq 15\text{mm}$), without any skin, meets the basic RCP requirements for PE100 pipe at 0 °C by either the full-scale or S4 test methods (see G.8). It is only in GIS/PL2 Part 2 that the peelable pipe, with its skin, is tested for RCP resistance down to 0 °C.

Therefore, for GIS/PL2 Part 1, the RCP test has to be conducted by the compound manufacturer only on one pipe size (without any skin) provided the wall thickness is 15mm or greater. For all sizes the test temperature is 0°C, with a full-scale test pressure of 14 bar for an SDR11 pipe or an equivalent S4 test pressure of 3.2 bar. In principle, a higher SDR (thinner-walled) pipe is acceptable but the wall thickness must still be 15 mm or greater but then the MOP has not been defined, which makes it difficult to set the test pressure of 2 x MOP.

The RCP test in GIS/PL2 Part 2 is conducted on a range of sizes: 250mm, 315mm and the manufacturer's maximum size e.g. 800mm. The polypropylene skin at low temperatures is

generally more brittle than the PE100 and so may result in crack initiation that can jump across the interface into the PE100 pipe core. Though the skin thicknesses are controlled in the Specification (Table 5, GIS/PL2-2, they are almost constant across the entire diameter range and the current tolerances are relatively wide. It will not become clear until further research is completed on effect of the skin, whether a relatively thick skin on a smaller diameter pipe is more likely to reduce the RCP resistance than a relatively thin skin on a larger diameter, thicker-walled pipe. Hence at this stage, it cannot be assumed that smaller pipe sizes would have higher critical pressure, so testing a range of sizes is currently required.

For GIS/PL2 Part 2, either the full-scale or S4 RCP test can be used. The full-scale test for all sizes is conducted at 0 °C at a test pressure of 4 bar using a PE80 SDR21/26 pipe as the initiation pipe if necessary (see G.4.1.2). The S4 test for all sizes is also conducted at 0 °C with a test pressure of 0.4 bar, as calculated from equation 1. Coincidentally, an S4 test temperature of approximately -20 °C is usually necessary to obtain the correct initiation conditions (see G.8).

If successful, approval is given to any smaller and intermediate pipe size, and is also conferred on any SDR26 pipe if the SDR21 pipe of equivalent OD has RCP approval (see GIS/PL2 Part 2: Table 13).

G.7 RCP Testing Multilayer Pipes

The specifications require multilayer pipes, where the inner layer is constructed from black PE80 compound and the outer layer is a yellow PE80 compound, have to be able to operate at temperatures down to -20°C and at operational pressures up to a MOP of 5.5 bar.

Multilayer pipes, where the inner layer is constructed from black PE100 compound and the outer layer is a yellow PE80 compound, have to be able to operate at temperatures down to only 0°C. As the pipes are only SDR21 or SDR26, the maximum operational pressure is 2 bar.

The RCP test for all types and sizes are conducted at 0°C. For all sizes, the full-scale test pressure will be 2 x MOP and for the S4 test, a pressure calculated from the equation (G.4.2). Either the full-scale or S4 test can be used. Again if the pipe fails the S4 test, it is permitted to re-test using the full-scale test, which if successful takes precedence, as the full-scale test is the reference test.

For GIS/PL2 Part 1, the RCP tests have to be conducted on both the PE100 and the PE80 compounds by the compound manufacturer(s) but only on one pipe size provided the wall thickness is 15mm or greater. For all sizes the test temperature is 0°C. The PE100 compound is to be tested at a full-scale test pressure of 14 bar for an SDR11 pipe or an equivalent S4 test pressure of 3.2 bar. In principle, a higher SDR (thinner-walled) pipe is acceptable (wall thickness must still be 15 mm or greater) but then the MOP for PE100 pipes has not been defined, which makes it difficult to set the test pressure of 2 x MOP. The PE80 compound is to be tested at a full-scale test pressure of 2 x maximum operating pressure (MOP) for the appropriate pipe size, SDR and 0°C temperature. The equivalent PE80 S4 test pressure at 0°C is calculated from equation 1 (G.4.2).

The RCP test in GIS/PL2 Part 2 is conducted on the manufacturer's maximum size of each type of multilayer pipe e.g. 225mm or 800mm. For GIS/PL2 Part 2, either the full-scale or S4 RCP test can be used. The full-scale test for all sizes is conducted at 0 °C at a test pressure of 2 x MOP using a PE80 as the initiation pipe for PE100 inner layer pipes, if necessary (see G.4.1.2). The S4 test for all sizes is also conducted at 0 °C with a test pressure calculated from equation 1. It is possible that an S4 test temperature of below 0 °C is necessary to obtain the correct initiation conditions in which case the S4 RCP test shall be conducted at this lower temperature but with the same test pressure (see G.8)

If successful, approval is given to any smaller and intermediate pipe size, and is also conferred on any SDR26 pipe if the SDR21 pipe of equivalent OD has RCP approval (see GIS/PL2 Part 2: Table 13).

G.8 RCP Testing PE100 Orange Pipes

The specifications require that all PE100 orange pipes (which are all SDR11) are able to operate at a MOP of 7 bar but, only at temperatures of 0 °C and above. RCP testing is identical whether they are constructed of all PE100 orange compound or are coextruded with a black PE100 inner layer and an orange PE100 outer layer.

Consequently, the RCP test for all sizes must be conducted at 0 °C. For all sizes the full-scale test pressure will be 14 bar and for the S4 test, a pressure of 3.2 bar. Either the full-scale or S4 test can be used. Again if the pipe fails the S4 test, it is permitted to re-test using the full-scale test, which if successful takes precedence, as the full-scale test is the reference test.

The full-scale method uses a PE80 crack initiation pipe length, butt welded onto the end of the PE100 test length (see G.4.1.2).

The S4 test can also be used for testing PE100 pipes. However, for the test to be valid it is necessary to prove the S4 initiation conditions can produce the start of a high speed crack into the test length (see BS EN ISO 13477). Otherwise, any crack arrest may have resulted from inadequate crack initiation rather than the pipe's test conditions (pressure, temperature, etc.). At 0 °C, suitable initiation conditions cannot be produced with modern PE100 compounds due to their high toughness, but it is possible to produce the required conditions at lower temperatures e.g. -20 °C. If, by using the same initiation conditions at the same low temperature, the S4 pipe test demonstrates crack arrest for the 3.2 bar test pressure, then the pipe would also show crack arrest at higher temperatures i.e. 0 °C. The RCP critical pressure never decreases on raising the temperature from -20 °C to 0 °C. Consequently, satisfactory RCP performance of the pipe would have been demonstrated for this pressure at 0 °C. Although the test is more severe than actually required, it is an effective way of addressing the problem of creating suitable crack initiation conditions. In practice, this test method works well with modern PE100 pipe compounds.

For GIS/PL2 Part 1, the RCP test has to be conducted by the manufacturer for each compound on one SDR11 pipe size provided the wall thickness is 15mm or greater. For all sizes the test temperature is 0°C, with a full-scale test pressure of 14 bar or a S4 test pressure of 3.2 bar.

For GIS/PL2 Part 8, the RCP test is conducted on the manufacturer's maximum pipe size, provided it has a wall thickness of 15mm or greater. For all sizes the test temperature is 0°C, with a full-scale test pressure of 14 bar or an S4 test pressure of 3.2 bar. If successful, approval is given to any smaller pipe size (see GIS/PL2 Part 8: Table 11 Note c).

G.9 Application of the Critical Pressure Data

The critical pressure obtained from full-scale tests (or converted from S4 critical pressures) on a particular PE pipe size and SDR is not normally used to predict the RCP performance of larger pipe sizes and/or different SDRs. All that can be inferred is that the critical pressures of the larger sizes will be not be higher for the same SDR. Conversely, if the critical pressure is known for a PE pipe size and SDR, then the critical pressure of a smaller pipe size, but of the same compound and SDR, will be higher. Naturally, this assumes the intrinsic RCP resistance of the PE compound/pipe batch is unchanged.

PE80 are designed to operate down to -20 °C, though the probability of operating at this temperature is not high. It has been estimated that a PE main buried at the normal burial depth of 750 mm may only reach 0 °C once in 50 years in the UK, though the reference data for this is now unknown.

However, downstream of a pressure reduction station (PRS) the gas expansion will decrease the temperature by approximately 0.5 °C per bar pressure reduction. For example, a pressure reduction from 19 bar to 4 bar will cause the temperature to drop by 7.5 °C. In winter, the gas may already be at a temperature of only +4 °C (for example), therefore the de-pressurised gas will be entering the downstream pipework at -3.5 °C. Naturally, the gas will warm as it travels along the pipeline so only a section will be affected by the sub-zero temperatures. The length of the section

can be estimated and so could be replaced by a length of cross-linked polyethylene (PE-X) pipe, which has very high RCP resistance down to -60 °C. The gas can also be preheated to avoid the problem but this is expensive in energy, and requires automatic back-up systems and long-term maintenance.

Low temperature gas can also occur in liquid petroleum gas (LPG) systems in winter. The gas is normally stored in tanks above ground which tend to attain the air temperature and this can be reduced further to well below zero, as vaporisation of the gas cools the gas and remaining liquid.

The effect on the pipe's RCP performance due to variability of the PE compound between batches is not known. In addition, the effects of different pipe manufacturers' production techniques (e.g. different extrusion conditions) on RCP performance have also not been evaluated. However, significant pipe-to-pipe RCP variability in PE80 or PE100 compounds has not been reported.

G.10 References

- 1) BS EN ISO 13478, Thermoplastics pipes for the conveyance of fluids — Determination of resistance to rapid crack propagation (RCP) — Full-scale test (FST).
- 2) BS EN ISO 13477, Thermoplastics pipes for the conveyance of fluids — Determination of resistance to rapid crack propagation (RCP) — Small-scale steady-state test (S4) test.

G.11 Decompression in Full-Scale and S4 RCP Tests

G.11.1 Pressure at the crack tip

The internal "gas" pressure at the crack tip is driving the crack forward, partly because of the hoop stress in the pipe wall but more importantly the "gas" exhausting radially is acting on the two flaps of pipe behind the crack tip so wedging open the crack. The crack tip pressure does not depend upon the pipe material and size, but only on the initial pressure, crack speed and some physical properties of the "gas". The formula gives the theoretical crack tip pressure for an infinitely long pipe line in any material. Measurements of the crack speed in the full-scale tests in PE pipes have shown that they have never exceeded the "gas" decompression speed.

$$\frac{p_t}{p_0} = \left[1 - \frac{\gamma - 1}{\gamma + 1} \left(1 - \frac{a}{c_0} \right) \right]^{\frac{2\gamma}{\gamma - 1}} \quad \text{when } a < c_0 \quad (2)$$

$$\frac{p_t}{p_0} = 1 \quad \text{when } a \geq c_0$$

where: -

p_t = absolute pressure at the crack tip

p_0 = initial pressure in the pipe

γ = ratio of specific heats of the "gas" (heat capacity ratio)

a = crack speed

c_0 = velocity of sound at 0 °C (decompression speed)

In using equation 2, the crack path is assumed to be axial and the speed constant but in reality the crack is usually wavy with a variety of speeds along its path, Figure G.1. Nevertheless, if the crack speed is constant, the pressure at the crack tip, though reduced from the original test pressure, is also constant (see Figure G.3 & equation 2). These "constant conditions" of crack tip pressure, pipe dimensions and properties continue to drive the crack forward indefinitely i.e. RCP conditions are produced.

As the crack speed slows and eventually stops, the ratio of a/c_0 tends to zero, however, the pressure in the pipe never falls below 28% of the original pressure for an infinitely long pipeline using a "gas" with a specific heat ratio, γ , of 1.4 i.e. air or nitrogen, Figure G.2.

$$\frac{p_t}{p_0} \Rightarrow 0.28 = \frac{1}{3.6} \quad (3)$$

G.11.2 Correlation equation

The full-scale RCP test simulates the fractured PE pipe in service during which the pressure at the crack tip is lower than originally set because the pipe pressure has reduced ahead of the crack tip, Figure G.3. The internal baffles in the S4 test method effectively stop axial decompression. Consequently, the pressure at the crack tip in the S4 test is always at the initial test pressure, whereas, for the Full-scale test, the pressure is reduced. As a result, the critical pressure measured in the S4 test will always be lower than the critical pressure in the full-scale test. A correlation between the two pressures is necessary.

As explained in the Full-scale test (BS EN ISO 13477), the crack speed slows and momentarily arrests (slip-stick) at test pressures near the critical pressure. The crack tip pressure will therefore fall almost instantaneously to the minimum value of 28% of the initial pressure i.e. the ratio of a/c approaches zero (equation 3). In the S4 test, the full test pressure will always be present. Consequently, the ratio of the critical pressures (absolute values) is given by: -

$$\frac{P_{cFS}}{P_{cS4}} = \frac{1}{0.28} = 3.6 \quad \text{absolute pressures}$$

$$\frac{P_{cFS} + 1}{P_{cS4} + 1} = 3.6 \quad \text{pressures in barg}$$

$$P_{cFS} = 3.6P_{cS4} + 2.6 \quad \text{barg}$$

Equation 4 does not depend upon the pipe material, size or SDR, but only on γ - ratio of specific heats C_p/C_v (Heat capacity ratio) of the "gas". The formula therefore only applies to nitrogen or air as the pressurising test "gas" because they have the same γ ratio of 1.40.

Several round-robin testing programmes to validate the formula have been completed (1). Typically, measured values of P_{cS4} on 250mm PE80 SDR11 pipes were in the range 1.0 - 1.5 barg so that on using the equation the calculated P_{cFS} range was 6.2 - 8.0 barg. This produced a direct correlation ratio in the range 5.3 - 6.2. Typical measured P_{cFS} on the same pipes are 7 barg to 9.6 barg, which are in reasonable agreement with the calculated range.

It seems that this correlation equation can be used with a reasonable degree of assurance, however, it must be pointed out that all the RCP data on which the correlation factors have been verified were obtained using 250mm SDR11 pipes and two very similar PE80 resins.

In practice, critical pressures from full-scale tests have generally exceeded the calculated "full-scale pressures" from the S4 method i.e. the correlation equation is conservative in predicting the actual critical pressures.

G.11.3 Testing using air/nitrogen instead of natural gas

Normally air or nitrogen is used for test purposes for which the decompression speeds at 0°C are 334m/s and 337m/s respectively. In comparison, natural gas (methane) has a higher decompression speed of 430m/s, though a lower heat capacity ratio, γ , of 1.31. Generally, the pressure at the crack tip in air/nitrogen is higher than for natural gas, though at speeds at 25-75m/s

as the crack arrests (slip-stick) the differences are negligible, Figure G.4.

Consequently, the critical pressure, PcFS measured in the full-scale test using air/nitrogen is not significantly different to that when using natural gas. Practical tests to demonstrate that there are no differences have not been conducted.

G.11.4 Reference

J M Greig, Rapid crack propagation in polyethylene gas pipes, Plastic Pipes IX Conference, Edinburgh, September 1995 (British Gas R&T Report No E949, August 1995).

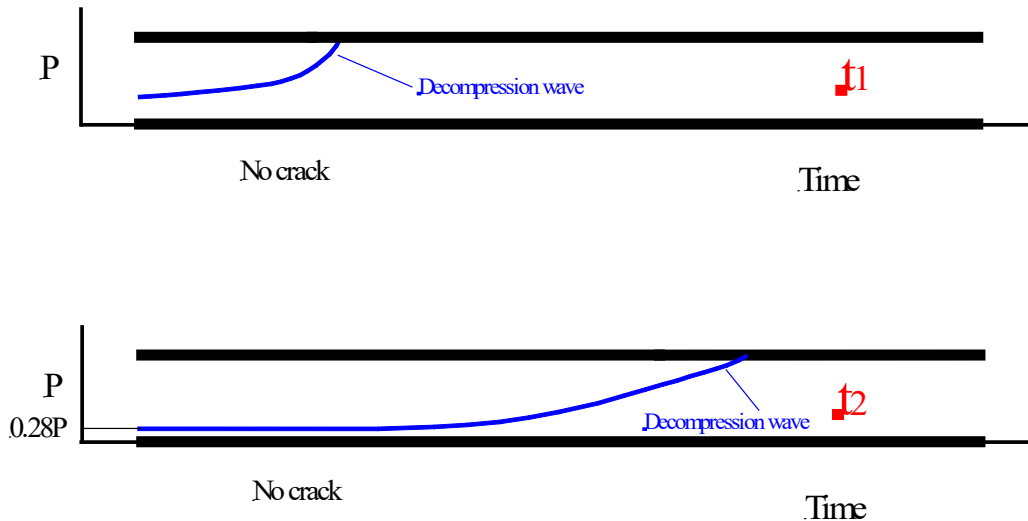

Figure G.2 A schematic of the pressure profile of a decompression wave travelling down a pipeline. For an infinitely long pipeline the pressure never reduces below 28% of the initial pressure for test gases nitrogen or air.

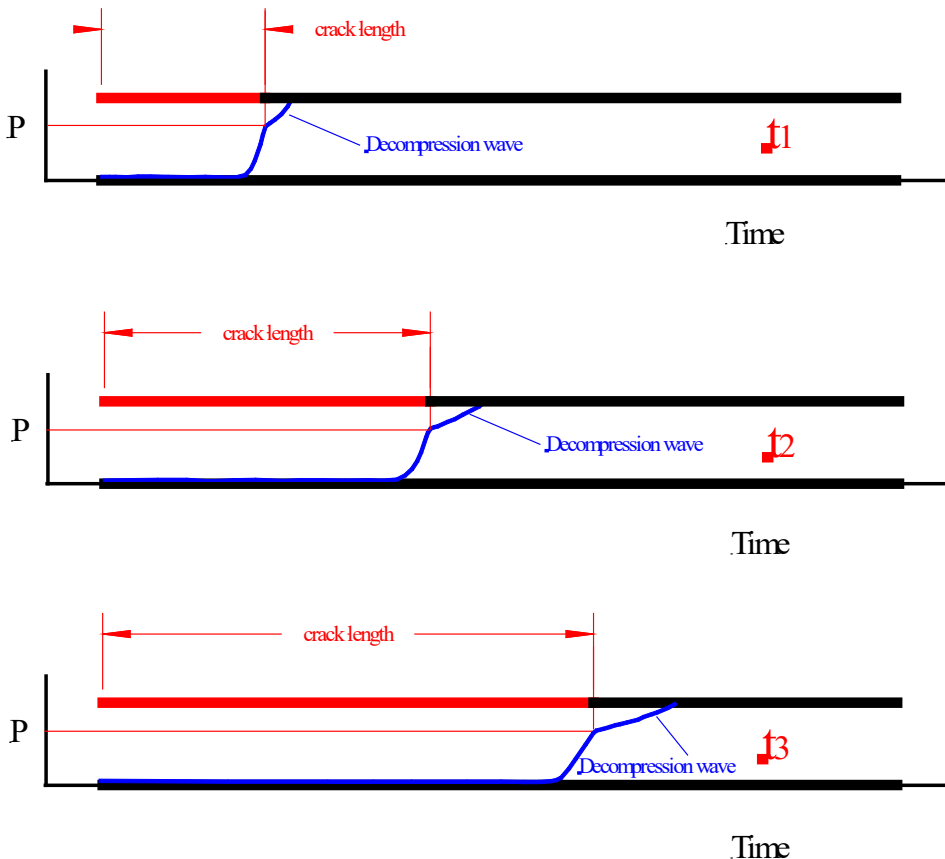

Figure G.3 A schematic of the pressure profile of a decompression wave travelling down a pipeline

followed by a crack. For constant crack speed, the pressure at the crack tip is constant.

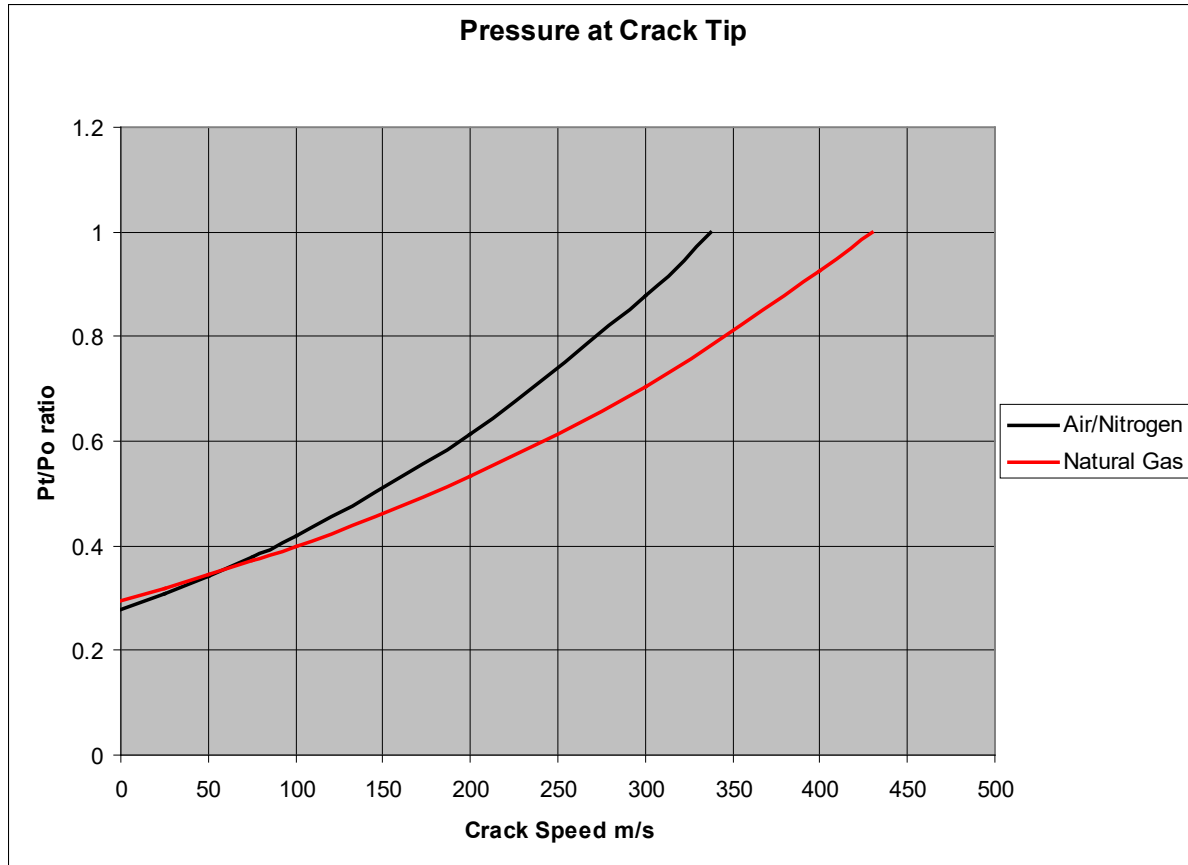

Figure G. 4 The pressure at the crack tip depends upon the crack speed but as the crack slows completely and starts to go into a slip–stick mode, the pressure differences are negligible between air/nitrogen and natural gas (plotted using equation 2).

G.12 Detailed RCP Pipe Specification Requirements (GIS/PL2-1/2 & 8)

G.12.1 RCP Testing PE80 Yellow Pipes (16-800mm) All SDRs

PE80 yellow pipes have to be able to operate at temperatures down to -20°C at pressures up to: -

- 5.5 bar for SDR11
- 4 bar for SDR 13.6
- 3 bar for SDR17.6
- 2 bar for SDR21 and SDR26

Due to RCP considerations, the maximum operating pressures (MOPs) of PE80 pipes in the larger sizes and lower temperatures have already been reduced (see GIS/PL2 Parts 1 & 2). Consequently, RCP tests are conducted at a temperature of 0 °C.

The correlation equation proposed by the ISO TC138/SC4 committee in producing BS EN ISO 13477 is: -

$$P_{FS} = 3.6P_{S4} + 2.6 \quad \text{bar} \quad (1)$$

where:

P_{FS} – full-scale pressure, bar

P_{S4} – S4 pressure, bar

G.12.1.1 GIS/PL2 Part 1

For GIS/PL2 Part 1, the RCP test shall be conducted by the compound manufacturer on one pipe size provided the wall thickness is 15 mm or greater.

A full-scale RCP test (BS EN ISO 13478) or an S4 RCP test (BS EN ISO 13477) shall be conducted.

The full-scale test shall be conducted at a temperature of 0°C and pressure of 2.0 x MOP. The MOP is selected for the appropriate pipe size, SDR and 0°C temperature.

The S4 test shall be conducted at a temperature of 0°C and a pressure (P_{S4}) calculated from Equation 1 using a full-scale pressure (P_{FS}) of 2.0 x MOP for the appropriate pipe size, SDR and 0°C temperature.

If the pipe fails the S4 test, it is permitted to re-test using the full-scale test, which if successful takes precedence, as the full-scale test is the reference test.

G.12.1.2 GIS/PL2 Part 2

For GIS/PL2 Part 2, the RCP test shall be conducted on the manufacture's maximum pipe size provided the wall thickness is 15mm or greater.

A full-scale RCP test (BS EN ISO 13478) or an S4 RCP test (BS EN ISO 13477) shall be conducted.

The full-scale test shall be conducted at a temperature of 0°C and pressure of 2.0 x MOP for the appropriate pipe size, SDR and 0°C temperature.

The S4 test shall be conducted at a temperature of 0°C and a pressure (P_{S4}) calculated from equation 1 using a full-scale pressure (PFS) of 2.0 x MOP for the appropriate pipe size, SDR and 0°C temperature.

If the pipe fails the S4 test, it is permitted to re-test using the full-scale test, which if successful takes precedence, as the full-scale test is the reference test.

If successful, approval is given to any smaller pipe size, provided the wall thickness is not greater than that tested.

G.12.2 RCP Testing Peelable (PE100) Yellow Pipes (225-800mm) SDR21 & 26

All peelable pipes (SDR21 and SDR26) with a PE100 core shall be able to operate at temperatures down to 0 °C and at operational pressures up to a MOP of 2 bar (see GIS/PL2 Parts 1 & 2).

G.12.2.1 GIS/PL2 Part 1

For GIS/PL2 Part 1, the RCP test shall be conducted by the compound manufacturer on one pipe size without the skin, provided the core wall thickness is 15mm or greater.

A full-scale RCP test (BS EN ISO 13478) or an S4 RCP test (BS EN ISO 13477) shall be conducted.

The full-scale test shall be conducted at a temperature of 0°C and pressure of 14 bar for SDR11 pipe.

The S4 test shall be conducted at a maximum temperature of 0°C and a pressure (P_{S4}) of 3.2 bar for SDR11 pipe.

If the pipe fails the S4 test, it is permitted to re-test using the full-scale test, which if successful takes precedence, as the full-scale test is the reference test.

G.12.2.2 GIS/PL2 Part 2

For GIS/PL2 Part 2, the RCP test shall be conducted on 250mm, 315mm and the manufacturer's maximum pipe size. The skins shall be present.

A full-scale RCP test (BS EN ISO 13478) or an S4 RCP test (BS EN ISO 13477) shall be conducted.

The full-scale test shall be conducted at a temperature of 0°C and pressure of 4 bar for SDR21/26

pipe.

The S4 test shall be conducted at a maximum temperature of 0°C and a pressure (P_{S4}) of 0.4 bar for SDR21/26 pipe.

If the pipe fails the S4 test, it is permitted to re-test using the full-scale test, which if successful takes precedence, as the full-scale test is the reference test.

If successful, approval is given to any smaller and intermediate pipe sizes and further to any SDR26 pipe if the SDR21 pipe has RCP approval.

G.12.3 RCP Testing Yellow Striped (PE80) Pipes – (16-225mm) All SDRs up to 5.5 bar

Yellow striped pipes with a PE80 compound shall be able to operate at temperatures down to -20 °C and at operational pressures up to a MOP of 5.5bar (see Annex B).

G.12.3.1 GIS/PL2-1

For GIS/PL2 Part 1, the RCP test shall be conducted by the compound manufacturer on one pipe size provided the wall thickness is 15 mm or greater.

A full-scale RCP test (BS EN ISO 13478) or an S4 RCP test (BS EN ISO 13477) shall be conducted.

The full-scale test shall be conducted at a temperature of 0°C and pressure of 2 x MOP. The MOP is selected for the appropriate pipe size, SDR and 0°C temperature.

The S4 test shall be conducted at a temperature of 0°C and a pressure (P_{S4}) calculated from Equation 1 (H.4.2) using a full-scale pressure (P_{FS}) of 2 x MOP for the appropriate pipe size, SDR and 0°C temperature.

If the pipe fails the S4 test, it is permitted to re-test using the full-scale test, which if successful takes precedence, as the full-scale test is the reference test.

G.12.3.2 GIS/PL2-2

For GIS/PL2-2, the RCP test shall be conducted on the manufacture's maximum pipe size provided the wall thickness is 15mm or greater.

A full-scale RCP test (BS EN ISO 13478) or an S4 RCP test (BS EN ISO 13477) shall be conducted.

The full-scale test shall be conducted at a temperature of 0°C and pressure of 2 x MOP for the appropriate pipe size, SDR and 0°C temperature.

The S4 test shall be conducted at a temperature of 0°C and a pressure (P_{S4}) calculated from equation 1 using a full-scale pressure (P_{FS}) of 2 x MOP for the appropriate pipe size, SDR and 0°C temperature.

If the pipe fails the S4 test, it is permitted to re-test using the full-scale test, which if successful takes precedence, as the full-scale test is the reference test.

If successful, approval is given to any smaller pipe size, provided the wall thickness is not greater than that tested.

G.12.4 RCP Testing Yellow Striped (PE100) Pipes – (225-800mm) SDR21 & 26

Yellow striped PE100 SDR21/26 pipes shall be able to operate at temperatures down to 0 °C and at operational pressures up to a MOP of 2bar (see Annex B).

G.12.4.1 GIS/PL2-1

For GIS/PL2 Part 1, the RCP test shall be conducted by the compound manufacturer on one pipe size provided the wall thickness is 15 mm or greater.

A full-scale RCP test (BS EN ISO 13478) or an S4 RCP test (BS EN ISO 13477) shall be conducted.

The full-scale test shall be conducted at a temperature of 0°C and pressure of 2 x MOP e.g. 14 bar for SDR11.

The S4 test shall be conducted at a maximum temperature of 0°C and a pressure (P_{S4}) of 3.2 bar for SDR11 pipe.

If the pipe fails the S4 test, it is permitted to re-test using the full-scale test, which if successful takes precedence, as the full-scale test is the reference test.

G.12.4.2 GIS/PL2-2

For GIS/PL2-2, the RCP test shall be conducted on the manufacturer's maximum pipe size provided the wall thickness is 15mm or greater.

A full-scale RCP test (BS EN ISO 13478) or an S4 RCP test (BS EN ISO 13477) shall be conducted.

The full-scale test shall be conducted at a temperature of 0°C and pressure of 4 bar (2 x MOP) for SDR21/26 pipe.

The S4 test shall be conducted at a maximum temperature of 0°C and a pressure (P_{S4}) of 0.4 bar for SDR21/26 pipe. .

If the pipe fails the S4 test, it is permitted to re-test using the full-scale test, which if successful takes precedence, as the full-scale test is the reference test.

If successful, approval is given to any smaller pipe size, provided the wall thickness is not greater than that tested.

G.12.5 RCP Testing Multilayer (PE80 inner layer) Pipes – (16-225mm) All SDRs up to 5.5 bar

Coextruded multilayer pipe with PE80 inner and PE80 outer layers shall be able to operate at temperatures down to -20 °C and at operational pressures up to a MOP of 5.5bar (see PL2-2, Annex B).

G.12.5.1 GIS/PL2-1

For GIS/PL2 Part 1, the RCP test shall be conducted by the compound manufacturer on one PE80 pipe size provided the wall thickness is 15 mm or greater.

A full-scale RCP test (BS EN ISO 13478) or an S4 RCP test (BS EN ISO 13477) shall be conducted.

The full-scale test shall be conducted at a temperature of 0°C and pressure of 2 x MOP. The MOP is selected for the appropriate pipe size, SDR and 0°C temperature.

The S4 test shall be conducted at a temperature of 0°C and a pressure (P_{S4}) calculated from Equation 1 (G.4.2) using a full-scale pressure (P_{FS}) of 2 x MOP for the appropriate pipe size, SDR and 0°C temperature.

If the pipe fails the S4 test, it is permitted to re-test using the full-scale test, which if successful takes precedence, as the full-scale test is the reference test.

G.12.5.2 GIS/PL2-2

For GIS/PL2-2, the RCP test shall be conducted on the manufacturer's maximum pipe size provided the wall thickness is 15mm or greater.

A full-scale RCP test (BS EN ISO 13478) or an S4 RCP test (BS EN ISO 13477) shall be conducted.

The full-scale test shall be conducted at a temperature of 0°C and pressure of 2 x MOP for the appropriate pipe size, SDR and 0°C temperature.

The S4 test shall be conducted at a temperature of 0°C and a pressure (P_{S4}) calculated from equation 1 using a full-scale pressure (P_{FS}) of 2 x MOP for the appropriate pipe size, SDR and 0°C temperature.

If the pipe fails the S4 test, it is permitted to re-test using the full-scale test, which if successful takes precedence, as the full-scale test is the reference test.

If successful, approval is given to any smaller pipe size, provided the wall thickness is not greater than that tested.

G.12.6 RCP Testing Multilayer (PE100 inner layer) Yellow Pipes – (225-800mm) SDR21 & 26 at up to 2 bar

All multilayer pipes (SDR21 and SDR26) with a PE100 inner layer and a PE80 outer layer shall be able to operate at temperatures down to 0 °C and at operational pressures up to a MOP of 2 bar (see Annex G.12).

G.12.5.3 GIS/PL2-1

For GIS/PL2-1, the RCP test shall be conducted by the compound manufacturer on one PE100 pipe size, provided the core wall thickness is 15mm or greater.

A full-scale RCP test (BS EN ISO 13478) or an S4 RCP test (BS EN ISO 13477) shall be conducted.

The full-scale test shall be conducted at a temperature of 0°C and pressure of 14 bar for SDR11 pipe. Alternatively, the S4 test shall be conducted at a maximum temperature of 0°C and a pressure (P_{S4}) of 3.2 bar for SDR11 pipe.

For the PE80 pipe material, the full-scale test shall be conducted on a PE80 pipe at a temperature of 0°C and pressure of 2 x maximum operating pressure (MOP) for the appropriate size, SDR and 0°C. The S4 test shall be conducted at a maximum temperature of 0°C and a pressure (P_{S4}) calculated for appropriate size and SDR using equation 1 (G.4.2).

If the pipe fails the S4 test, it is permitted to re-test using the full-scale test, which if successful takes precedence, as the full-scale test is the reference test.

G.12.5.4 GIS/PL2-2

For GIS/PL2- 2, the RCP test shall be conducted on the maximum pipe size provided it has a wall thickness of 15mm or greater.

A full-scale RCP test (BS EN ISO 13478) or an S4 RCP test (BS EN ISO 13477) shall be conducted.

The full-scale test shall be conducted at a temperature of 0°C and pressure of 4 bar for SDR21/26 pipe.

The S4 test shall be conducted at a maximum temperature of 0°C and a pressure (P_{S4}) of 0.4 bar for SDR21/26 pipe.

If the pipe fails the S4 test, it is permitted to re-test using the full-scale test, which if successful takes precedence, as the full-scale test is the reference test.

If successful, approval is given to any smaller and intermediate pipe sizes and further to any SDR26 pipe if the SDR21 pipe has RCP approval.

G.12.6 RCP Testing PE100 orange Pipes (32-630mm) SDR11 up to 7 bar

All PE100 orange SDR11 pipes, including co-extruded PE100/PE100 multilayer SDR11 pipes, shall be able to operate at a MOP of 7 bar but only for temperatures of 0 °C and above (see GIS/PL2-8).

G.12.6.1 GIS/PL2 Part 1

For GIS/PL2 Part 1, the RCP test shall be conducted by the compound manufacturer on one pipe size for each PE100 compound, provided the wall thickness is 15mm or greater.

A full-scale RCP test (BS EN ISO 13478) or an S4 RCP test (BS EN ISO 13477) shall be conducted.

The full-scale test shall be conducted at a temperature of 0°C and pressure of 14 bar (SDR11).

The S4 test shall be conducted at a maximum temperature of 0°C and a pressure (P_{S4}) of 3.2 bar (SDR11).

If the pipe fails the S4 test, it is permitted to re-test using the full-scale test, which if successful takes precedence, as the full-scale test is the reference test.

G.12.6.2 GIS/PL2 Part 8

For GIS/PL2 Part 8, the RCP test shall be conducted on the manufacturer's maximum pipe size, provided it has a wall thickness of 15mm or greater

A full-scale RCP test (BS EN ISO 13478) or an S4 RCP test (BS EN ISO 13477) shall be conducted.

The full-scale test shall be conducted at a temperature of 0°C and pressure of 14 bar (SDR11).

The S4 test shall be conducted at a maximum temperature of 0°C and a pressure (P_{S4}) of 3.2 bar (SDR11).

If the pipe fails the S4 test, it is permitted to re-test using the full-scale test, which if successful takes precedence, as the full-scale test is the reference test.

If successful, approval is given to any smaller pipe size, provided the wall thickness is not greater than that tested.

**Annex - H Summary of and Rationale for changes to document – December 2014
(increase pipe sizes to 630mm).**

GIS/PL2-8 Clause	Comment & Rationale	Proposer	Action Required (if applicable)
General	Update references	M Greig	Update ISO & EN references
Scope	Increase pipe sizes to 630mm.	D Robinson	Insertion of nominal pipe size range 16 to 630mm.
Table 3	Increase size range to 630mm	D Robinson	Add 560mm& 630mm SDR11 sizes
Table 6 Note a	Alternative testing options for mature suppliers	D Robinson	Text added identical to PL2-2
Table 6 Note h	Update MOPs reference	D Robinson	Reference MOPs to Annex E
Clause 11	Update MOPs reference and include the equations	M Greig	Reference MOPs to Annex E and the equations from PL2-2
Table 12	Increase Size Group 3 to 630mm	D Robinson	Replace 500 by 630 in size group 3
Table 13	Change sample frequency to weekly to reflect PL2-2	D Robinson	Change sample frequency from one sample/size/week to weekly
Annex B.2	Increase test pipe size range option from 125mm to 75-250mm	D Robinson	Change size range option to 75-250mm
Table E.1	Increase size range to 630mm	D Robinson	Add 560mm& 630mm SDR11 sizes
Annex G	Update to reflect recent changes in PL2-2	M Greig	Copy changes in PL2-2 Annex H into Annex G

Annex - I **Changes to Document January 2022****I.1 Technical Standards Forum changes**

Scope 1 st Paragraph	To broaden, text amended Deleted “Orange”, replaced “32” with “16”, and “630” with “800”
Scope 2nd Paragraph	Text revised to provide flexibility whereby customers / GDNs may want higher SDRs. 2nd Paragraph – delete “Also” and replace “multilayer” with “all combinations of” and replace “consisting of a co extruded black PE100 inner layer and an orange PE100 outer layer in sizes 32-630mm SDR 11 with “unimodal and bimodal”
References 2.1	References of standards not used within this standard deleted. References added as required. Titles and full references added
Section 4	Section 4 “Conformance” added and sections that follow renumbered. Internal references also amended.
Table 9	Table 9 amended to add requirements for crushing test to BS ISO 13955.
Table 13	Table 13 – Note 1 “again” replaced by “repeated”
Section 15	Text added at 15.4 to allow the option of contractors suggesting alternative marking arrangements.
Annex E	At end of Annex E the bibliography has been moved to Section 2 References.
Annex G	Annex G 3rd level heading numbering added for sub section related to GIS/PL2 Part 1 & GIS/PL2-2 and to GIS/PL2-2 Part 8.
Annex G	At Annex G.5 & G.12.1 Text added “4 bar for SDR 13.6”
Annex G	At G.6 “National Grid” replaced by “Gas Transporter”
Annex G	References to Appendix G.A replaced by Annex G.11
Annex G	References to Appendix G.B replaced by Annex G.12
Annex G	Bibliography at end of document removed, references are now placed in Section 2.1